

MIA

Design Vistosi

MIA PL 60

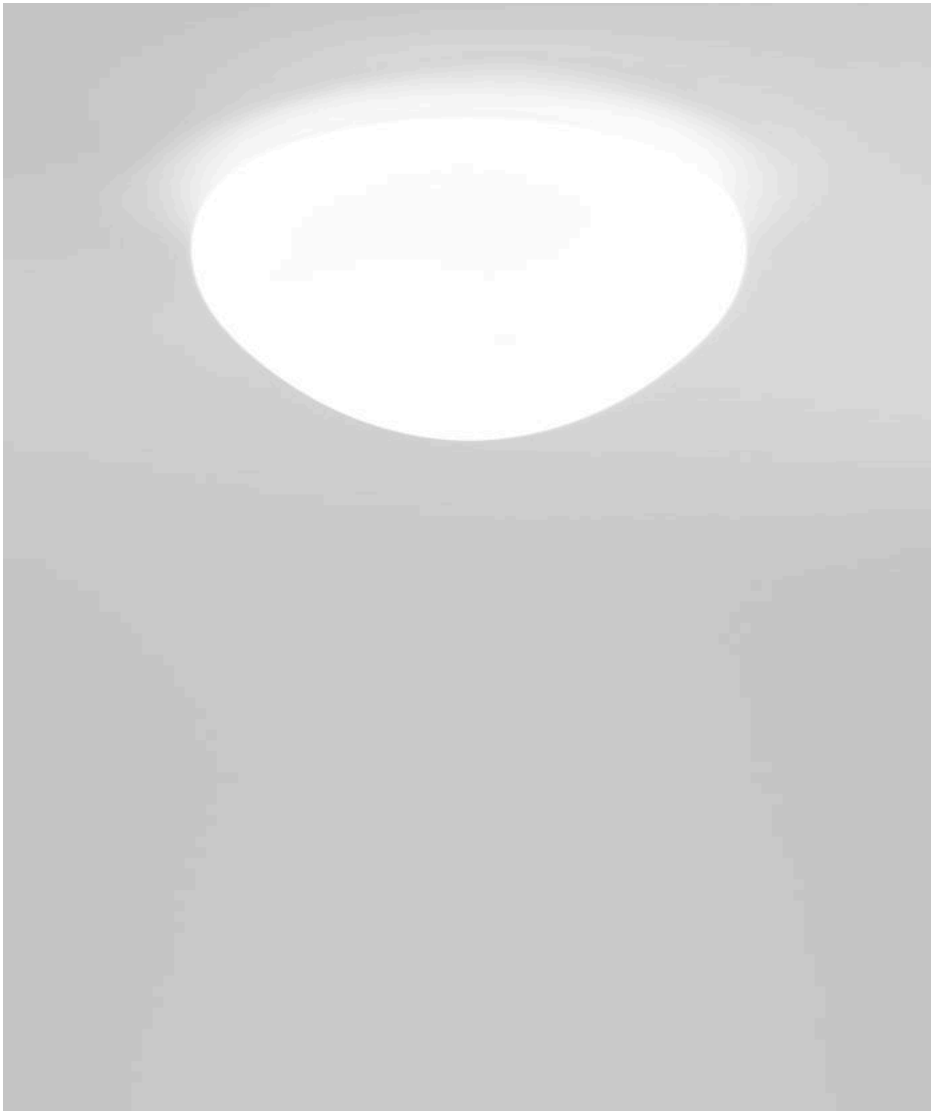

The ceiling lamp is characterized by a simple line, gently rounded in the upper part. It provides an excellent adhesion to the support, thanks to the frame that minimizes the distance from the ceiling.

MIA PL 60

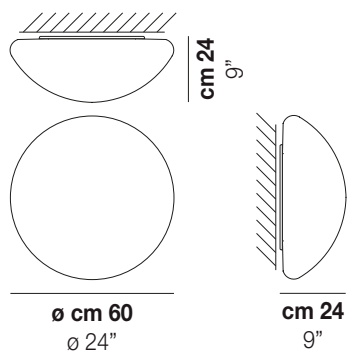

TECHNICAL DATA:

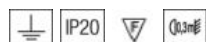

CERTIFICATIONS:



LIGHT SOURCES

3x77W 220-240 V E27
50/60 Hz

VOLUME Mc 0,21
GROSS WEIGHT Kg 10,5
NET WEIGHT Kg 6,5

[download](#)



SHADE FINISHING

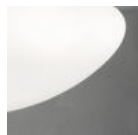

BCST

FRAME FINISHING



BC

MIA

Design Vistosi

MIA PL 60



The ceiling lamp is characterized by a simple line, gently rounded in the upper part. It provides an excellent adhesion to the support, thanks to the frame that minimizes the distance from the ceiling.

MIA PL 60

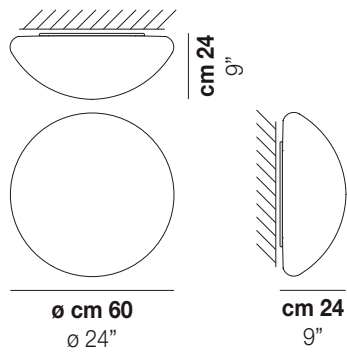

TECHNICAL DATA:



CERTIFICATIONS:



VOLUME	Mc 0
GROSS WEIGHT	Kg 10,5
NET WEIGHT	Kg 6,5

download



SHADE FINISHING



BCST

FRAME FINISHING



BC

MIA

Design Vistosi

MIA PL 60

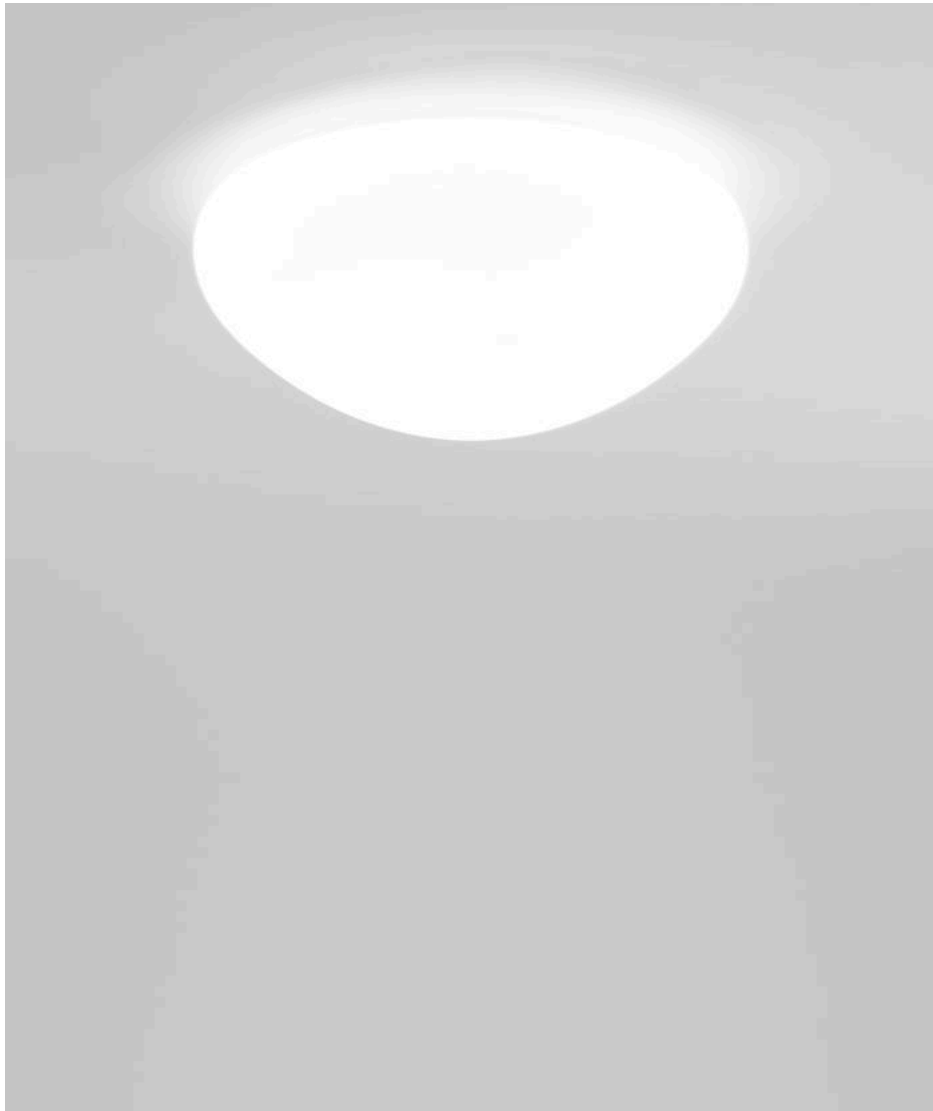

The ceiling lamp is characterized by a simple line, gently rounded in the upper part. It provides an excellent adhesion to the support, thanks to the frame that minimizes the distance from the ceiling.

MIA PL 60

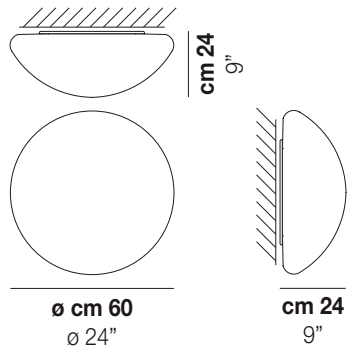

TECHNICAL DATA:



CERTIFICATIONS:



VOLUME	Mc 0
GROSS WEIGHT	Kg 10,5
NET WEIGHT	Kg 6,5

download



SHADE FINISHING



BCST

FRAME FINISHING



BC

MIA

Design Vistosi

MIA PL 60



The ceiling lamp is characterized by a simple line, gently rounded in the upper part. It provides an excellent adhesion to the support, thanks to the frame that minimizes the distance from the ceiling.

MIA PL 60

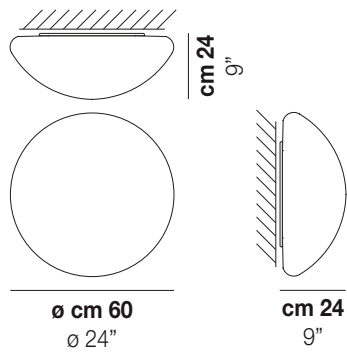

TECHNICAL DATA:



CERTIFICATIONS:



VOLUME	Mc 0
GROSS WEIGHT	Kg 10,5
NET WEIGHT	Kg 6,5

download



SHADE FINISHING

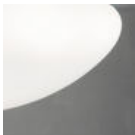

BCST

FRAME FINISHING



BC

MIA

Design Vistosi

MIA PL 60

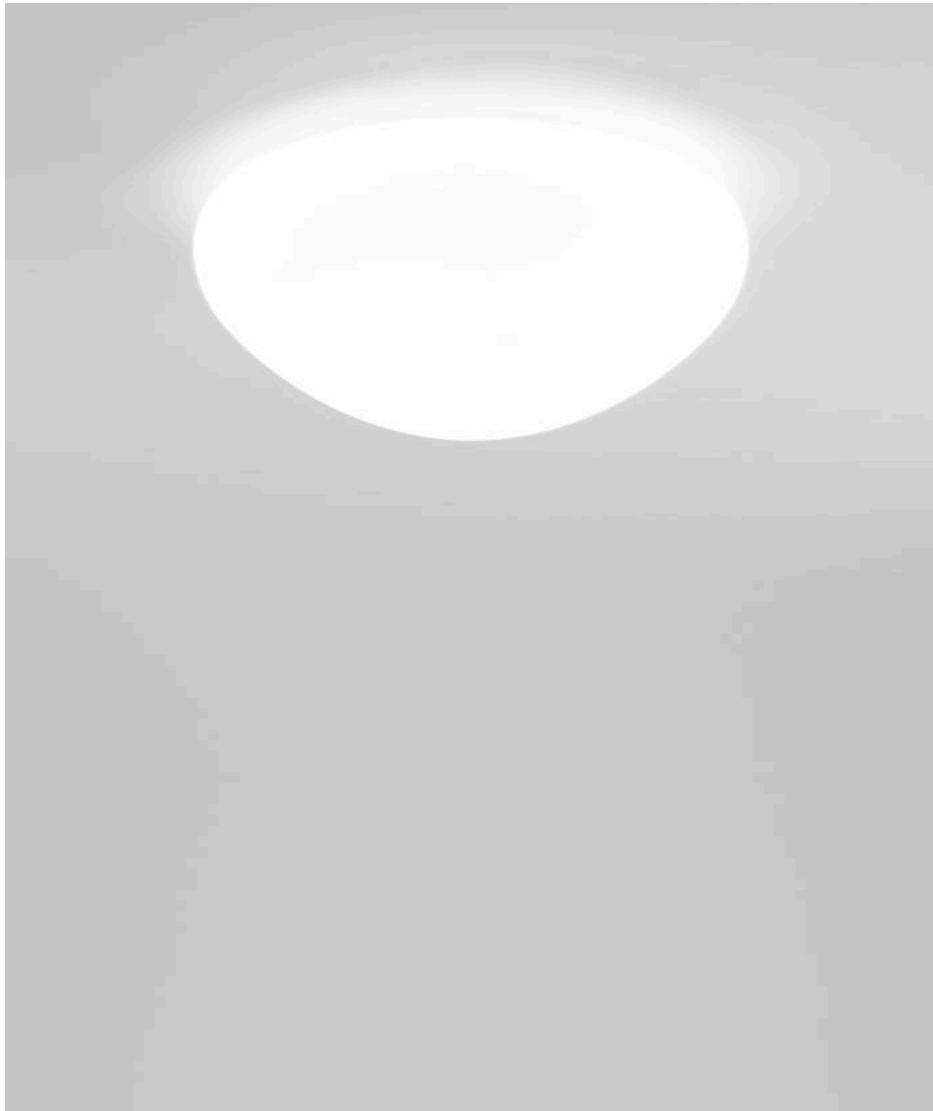

The ceiling lamp is characterized by a simple line, gently rounded in the upper part. It provides an excellent adhesion to the support, thanks to the frame that minimizes the distance from the ceiling.

MIA PL 60

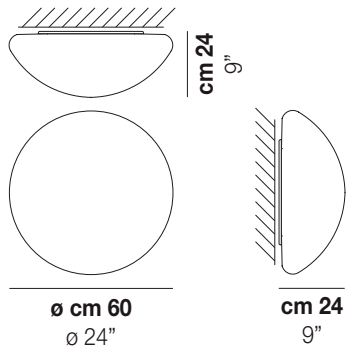

TECHNICAL DATA:



CERTIFICATIONS:



VOLUME	Mc 0,21
GROSS WEIGHT	Kg 10,5
NET WEIGHT	Kg 6,5

download



SHADE FINISHING



BCST

FRAME FINISHING



BC