

Cadira



collection booklet

collection booklet

Cadira / Cadira S

Design **Studio Sovet**

“
A seating with an enveloping and comfortable shape that matches with elegance and simplicity the tables of Sovet’s collection. The Cadira chair finishes, from leather and fake leather to fabric and velvet, complete the different types of structure making it adapt for any kind of public or private space.

Una seduta dalla forma comoda ed avvolgente che accompagna con raffinatezza e semplicità i tavoli della collezione Sovet. Le finiture di Cadira, dalla pelle e ecopelle fino al tessuto e al velluto, si uniscono a diverse tipologie di struttura personalizzando la seduta per gli interni pubblici e privati.

”

Models & Dimensions

Cadira

Girevole

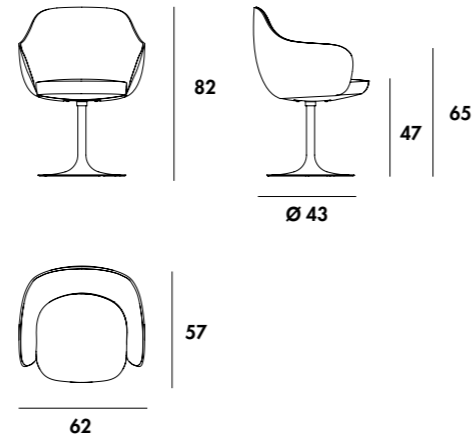

Cone shaped

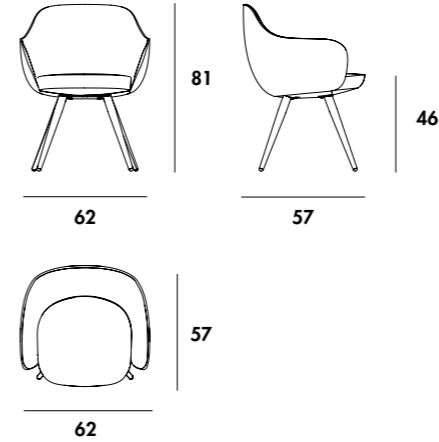

Wire

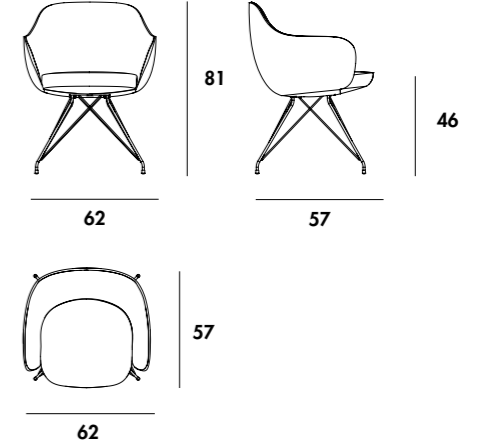

Cadira S

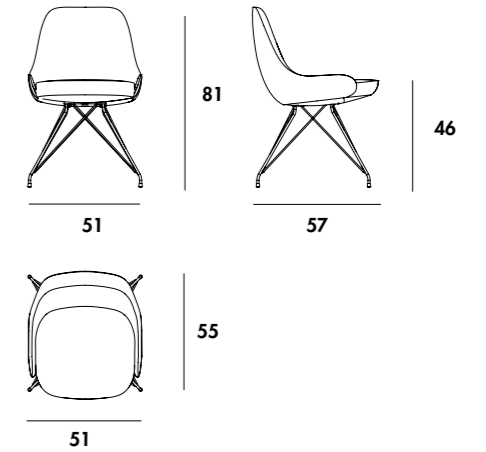
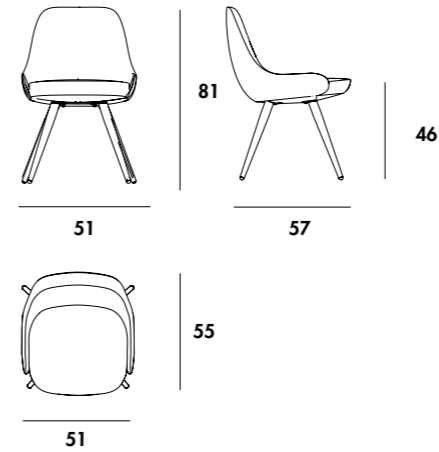
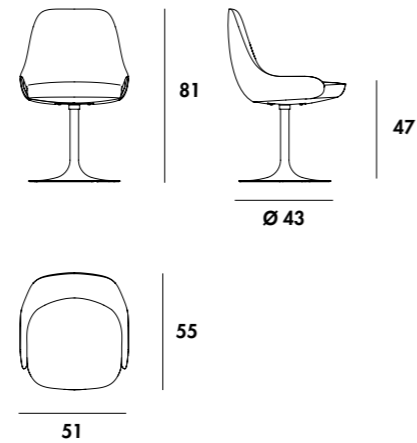

one collection for more than 200 settings



collection
finishes



coverings

Kvadrat Hallingdal 65

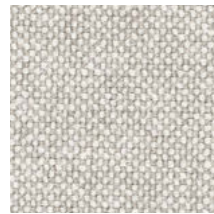

103

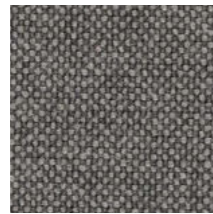

153

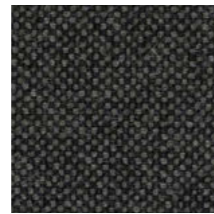

173



190



390

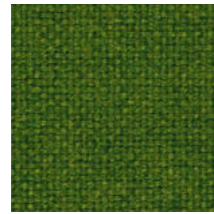

960



764

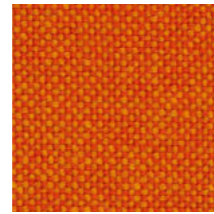

590

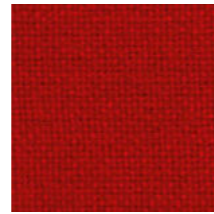

674

COMPOSITION

COMPOSIZIONE

Fabric composed by new wool (70%) and viscose (30%).

Tessuto composto da lana (70%) e viscosa (30%).

USE AND MAINTENANCE

- Dust regularly the fabric.
- Normal spots can be cleaned with a slightly damp cloth and a mild soap. In case of particular spots please contact a professional dry cleaner.
- After the treatment dry immediately the fabric without exposing it to direct sunlight or excessive heat.
- Do not rub. Swab the stain using a slight circular motion towards the centre.
- Avoid the contact between light colour fabrics and clothings coloured with unfixed dyes.

USO E MANUTENZIONE

- Spolverare regolarmente il tessuto.
- Eventuali macchie normali si possono eliminare usando un panno inumidito con acqua e sapone neutro. Per macchie particolari, contattare un centro lavasecco professionale.
- Asciugare immediatamente dopo il trattamento senza esporre il tessuto alla luce diretta o a forti fonti di calore.
- Non strofinare, tamponare delicatamente partendo dai bordi fino al centro della macchia.
- I colori chiari non devono essere messi a contatto con tessuti e capi d'abbigliamento trattati con coloranti non fissati.

Technical data are available in the section "materials" on www.sovet.com. More info on kvadrat.dk.

Per i dati tecnici consultare la sezione materiali su www.sovet.com. Altre informazioni su kvadrat.dk.

Gabriel Trevira CS

Step



F10

Beige
Beige

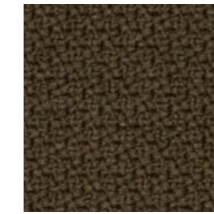

F11

Mocha
Caffé

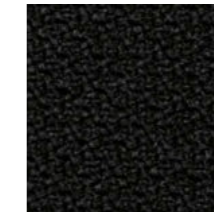

F12

Black
Nero

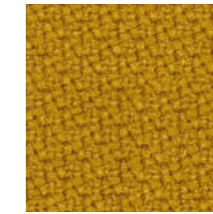

F13

Mustard
Senape

Step melange

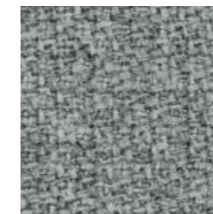

F01

Grey
Grigio

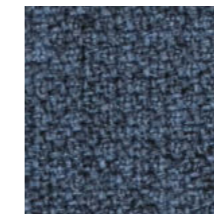

F02

Avio
Avio

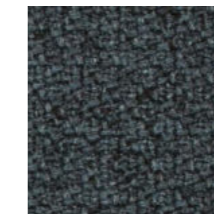

F03

Dark Teal
Ottone scuro



F04

Dark Brown
Marrone testa di moro



F05

Carmine
Carminio

COMPOSITION

COMPOSIZIONE

100% Trevira cs

Technical data are available in the section "materials" on www.sovet.com. More info on gabriel.dk.

Per i dati tecnici consultare la sezione materiali su www.sovet.com. Altre informazioni su gabriel.dk.

USE AND MAINTENANCE

- Dust regularly the fabric.
- Normal spots can be cleaned with a slightly damp cloth and a mild soap. In case of particular spots please contact a professional dry cleaner.
- After the treatment dry immediately the fabric without exposing it to direct sunlight or excessive heat.
- Do not rub. Swab the stain using a slight circular motion towards the centre.
- Avoid the contact between light colour fabrics and clothings coloured with unfixed dyes.

USO E MANUTENZIONE

- Spolverare regolarmente il tessuto.
- Eventuali macchie normali si possono eliminare usando un panno inumidito con acqua e sapone neutro. Per macchie particolari, contattare un centro lavasecco professionale.
- Asciugare immediatamente dopo il trattamento senza esporre il tessuto alla luce diretta o a forti fonti di calore.
- Non strofinare, tamponare delicatamente partendo dai bordi fino al centro della macchia.
- I colori chiari non devono essere messi a contatto con tessuti e capi d'abbigliamento trattati con coloranti non fissati.

Velvet Velluto



Z01
Light grey
Grigio chiaro



Z02
Khaki
Cachi



Z03
Taupe color
Color talpa



Z04
Grey
Grigio



Z05
Anthracite
Antracite



Z06
Light blue
Azzurro



Z08
Yellow
Giallo



Z09
Brick red
Rosso mattone



Z10
Olive green
Verde oliva

Leather Pelle

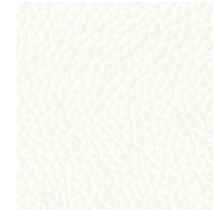

P50
White
Bianco

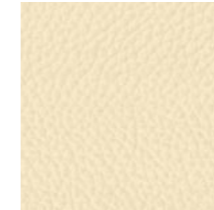

P63
Off-white
Panna

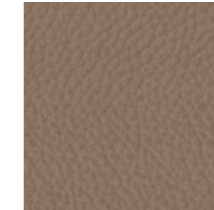

P64
Umber
Terra



P61
Brown
Marrone

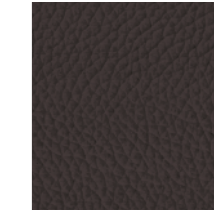

P54
Mocha
Caffè

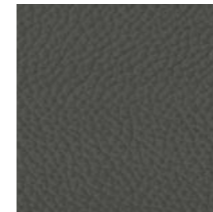

P65
Grey
Grigio

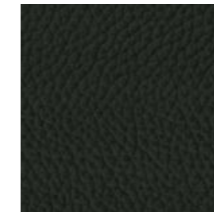

P53
Black
Nero

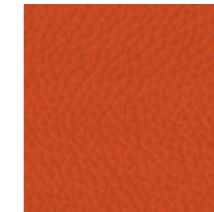

P66
Orange
Arancio

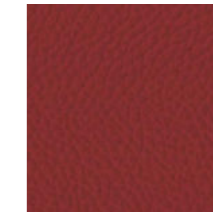

P62
Burgundy
Borgogna

COMPOSITION

COMPOSIZIONE

92% PES, 5% CO, 3% LA.

USE AND MAINTENANCE

- Dust regularly the velvet.
- Normal spots can be cleaned with a slightly damp cloth and a mild soap. In case of particular spots please contact a professional dry cleaner.
- After the treatment dry immediately the velvet without exposing it to direct sunlight or excessive heat.
- Do not rub. Swab the stain using a slight circular motion towards the centre.
- Avoid the contact between light colour velvets and clothings coloured with unfixed dyes.

USO E MANUTENZIONE

- Spolverare regolarmente il velluto.
- Eventuali macchie normali si possono eliminare usando un panno inumidito con acqua e sapone neutro. Per macchie particolari, contattare un centro lavasecco professionale.
- Asciugare immediatamente dopo il trattamento senza esporre il velluto alla luce diretta o a forti fonti di calore.
- Non strofinare, tamponare delicatamente partendo dai bordi fino al centro della macchia.
- I colori chiari non devono essere messi a contatto con tessuti e capi d'abbigliamento trattati con coloranti non fissati.

Technical data are available in the section "materials" on www.sovet.com. More info on www.glamour-textiles.it

Per i dati tecnici consultare la sezione materiali su www.sovet.com. Altre informazioni su www.glamour-textiles.it

COMPOSITION

COMPOSIZIONE

Chrome tanned bovine leather of European origin. Thickness 1.0 - 1.2 mm.
Pelle bovina di origine europea conciata al cromo. Spessore 1.0 - 1.2 mm.

USE AND MAINTENANCE

- Dust regularly the leather.
- Normal spots can be cleaned with a slightly damp cloth and a mild soap. In case of particular spots please contact a professional dry cleaner.
- After the treatment dry immediately the leather without exposing it to direct sunlight or excessive heat.
- Do not rub. Swab the stain using a slight circular motion towards the centre.
- Avoid the contact between light colour leathers and clothings coloured with unfixed dyes.

USO E MANUTENZIONE

- Spolverare regolarmente la pelle.
- Eventuali macchie normali si possono eliminare usando un panno inumidito con acqua e sapone neutro. Per macchie particolari, contattare un centro lavasecco professionale.
- Asciugare immediatamente dopo il trattamento senza esporre la pelle alla luce diretta o a forti fonti di calore.
- Non strofinare, tamponare delicatamente partendo dai bordi fino al centro della macchia.
- I colori chiari non devono essere messi a contatto con tessuti e capi d'abbigliamento trattati con coloranti non fissati.

Technical data are available in the section "materials" on www.sovet.com. More info on www.gruppodani.com

Per i dati tecnici consultare la sezione materiali su www.sovet.com. Altre informazioni su www.gruppodani.com

Ecopelle Fake Leather

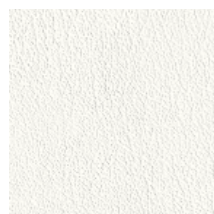

E01
White
Bianco



E02
Off-White
Panna

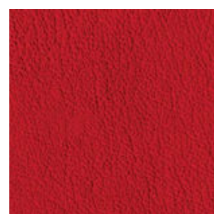

E03
Rosso
Red



E04
Nero
Black



E05
Mocha
Caffè

COMPOSITION

COMPOSIZIONE

Coated fabric created by using innovative and high resistant components, without using phthalates.

Tessuto spalmato realizzato con materiali innovativi ad alta resistenza, senza l'utilizzo di ftalati.

USE AND MAINTENANCE

- Dust regularly the fake leather.
- Normal spots can be cleaned with a slightly damp cloth and a mild soap. In case of particular spots please contact a professional dry cleaner.
- After the treatment dry immediately the fake leather without exposing it to direct sunlight or excessive heat.
- Do not rub. Swab the stain using a slight circular motion towards the centre.
- Avoid the contact between light colour fake leathers and clothings coloured with unfixed dyes.

USO E MANUTENZIONE

- Spolverare regolarmente l'ecopelle.
- Eventuali macchie normali si possono eliminare usando un panno inumidito con acqua e sapone neutro. Per macchie particolari, contattare un centro lavasecco professionale.
- Asciugare immediatamente dopo il trattamento senza esporre l'ecopelle alla luce diretta o a forti fonti di calore.
- Non strofinare, tamponare delicatamente partendo dai bordi fino al centro della macchia.
- I colori chiari non devono essere messi a contatto con tessuti e capi d'abbigliamento trattati con coloranti non fissati.

Per i dati tecnici consultare la sezione materiali su www.sovet.com. Altre informazioni su www.flukso.it.

Technicals data are available in the section "materials" on www.sovet.com. More info on www.flukso.it.

Ecopelle Nabuk Rebel Rebel Nabuk Fake Leather

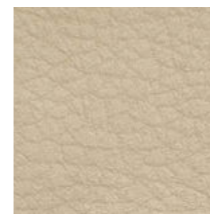

R21

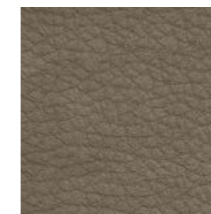

R23



R25



R26

COMPOSITION

COMPOSIZIONE

Distressed fireproof coated fabric, Made in Italy.

Tessuto spalmato ignifugo Made in Italy dall'aspetto vissuto.

USE AND MAINTENANCE

- Dust regularly the fake leather.
- Normal spots can be cleaned with a slightly damp cloth and a mild soap. In case of particular spots please contact a professional dry cleaner.
- After the treatment dry immediately the fake leather without exposing it to direct sunlight or excessive heat.
- Do not rub. Swab the stain using a slight circular motion towards the centre.
- Avoid the contact between light colour fake leathers and clothings coloured with unfixed dyes.

USO E MANUTENZIONE

- Spolverare regolarmente l'ecopelle.
- Eventuali macchie normali si possono eliminare usando un panno inumidito con acqua e sapone neutro. Per macchie particolari, contattare un centro lavasecco professionale.
- Asciugare immediatamente dopo il trattamento senza esporre l'ecopelle alla luce diretta o a forti fonti di calore.
- Non strofinare, tamponare delicatamente partendo dai bordi fino al centro della macchia.
- I colori chiari non devono essere messi a contatto con tessuti e capi d'abbigliamento trattati con coloranti non fissati.

Per i dati tecnici consultare la sezione materiali su www.sovet.com. Altre informazioni su www.flukso.it.

Technicals data are available in the section "materials" on www.sovet.com. More info on www.flukso.it.

bases

Metals Metalli

wire



GN
Embossed black
Nero goffrato



GC
Embossed mocha
Caffè goffrato



GT
Embossed clay
Creta goffrato



GB
Embossed white
Bianco goffrato



BR
Burnished metal
Metallo brunito

cone shaped



GN
Embossed black
Nero goffrato



GC
Embossed mocha
Caffè goffrato



GT
Embossed clay
Creta goffrato



GB
Embossed white
Bianco goffrato



BR
Burnished metal
Metallo brunito

girevole



GN
Embossed black
Nero goffrato



GC
Embossed mocha
Caffè goffrato



GT
Embossed clay
Creta goffrato

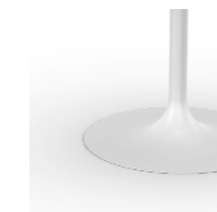

GB
Embossed white
Bianco goffrato

Materiali e manutenzione

ITA

Metalli

I colori dei metalli sono campioni indicativi. Pulire utilizzando un panno morbido inumidito.

Tessuti/Pelli/Ecopelli/Velluti

I colori dei tessuti sono campioni indicativi. Per la cura e la manutenzione fare riferimento alle indicazioni riportate nelle rispettive cartelle e alle schede tecniche fornite dai produttori.

Se permangono dubbi contattare l'azienda.

Colours and maintenance

ENG

Metals

Metals colours are indicative samples. Clean using a damp soft cloth.

Fabrics/Leathers/Fake leathers/velvets

Fabrics colours are indicative samples. For care and maintenance please refer to the instructions present in the corresponding folders and to the technical sheets provided by the manufacturers.

In case of further doubt please get in touch with the factory.









designer

Studio Sovet

Studio Sovet is the development and design department of SO.VE.T. The team is composed of a group of figures that collaborate to create unique projects. For SOVETITALIA the good design raises in fact from the dialogue of ideas and concepts between people. The richness of this exchange leads to create unique products that resonate with their inner meanings of wisdom, craftsmanship and technology. These are the strengths of a company that has quality, design and service as a primary mission.

Studio Sovet è il dipartimento di sviluppo e progettazione di SO.VE.T. Il team è composto da un insieme di figure che collaborano tra di loro per creare progetti unici. Per SOVETITALIA il buon design, infatti, nasce dal dialogo di idee e concetti tra le persone. La ricchezza di questo scambio porta a creare dei prodotti unici che richiamino al loro interno i significati di sapienza, artigianalità e tecnologia. Questi sono i punti di forza di un'azienda che fa della qualità, del design e del servizio al cliente una mission.

SOVET
ITALIA

sustainability is made up of facts.

Sovet has always maintained a high attention to eco-compatibility since its birth in its birth in 1987, through the selection of raw materials and the study of production processes that have the least impact on the environment with the aim of creating long-lasting products.

Sovet ha sempre mantentenuo alta l'attenzione all'ecocompatibilità sin dalla sua nascita nel 1987, attraverso la selezione delle materie prime e lo studio di processi produttivi che abbiano il minimo impatto sull'ambiente con lo scopo di creare prodotti durevoli nel tempo.

photovoltaic systems



For its production processes Sovet uses energy coming directly from renewable sources. Thanks to its photovoltaic systems it is able to meet its own energy demand.

Per la sua produzione Sovet utilizza infatti energia derivante direttamente da fonti rinnovabili. Attraverso impianti fotovoltaici riesce a soddisfare il proprio fabbisogno energetico.



502695,549 kg emmission saved per year



2989 tree saved per year



165 barrel of oil saved per year

packiging



Sovet uses cardboard packaging with limited presence of oil-derivate.

Sovet usa imballi di cartone costruiti ad hoc con limitata presenza di derivati del petroli.



reduce plastic is an habits



To reduce the consumption of plastic and disposable bottles within its offices and production, Sovet created metal water bottles.

Per ridurre il consumo di plastica e bottiglie monouso all'interno dei suoi uffici e della produzione, Sovet ha creato delle borracce in metallo.

made in italy

The creative use of industrial processes, the use of raw materials of absolute quality and the scrupulous work of master craftsmen, allow Sovet to create high quality and 100% Made in Italy collections. Thanks to state-of-the-art industrial automation systems, Sovet is able to meet also large supply needs for contract spaces, always granting the highest quality standards. The company takes a continuous search path for materials, to create an offer of accessories complementing one another, furnishing different kinds of environments with the maximum customization possibility.

L'impiego creativo dei processi industriali, l'utilizzo di materie prime di assoluta qualità e le scrupolose lavorazioni eseguite da maestranze artigiane, permettono a Sovet di ottenere collezioni di alta qualità e 100% Made in Italy. Grazie a sistemi di automazione industriale all'avanguardia Sovet è in grado di soddisfare anche esigenze per grandi forniture destinate a spazi contract, sempre garantendo i più elevati standard qualitativi. Sovet intraprende un percorso di ricerca dei materiali per creare un'offerta di complementi che si integrino tra di loro, arredando varie tipologie di ambienti con la massima possibilità di personalizzazione.

