

# LAMPE DE MARSEILLE

*Le Corbusier*

Designed by Le Corbusier for the Unité d'Habitation of Marseille in 1949/1952, it is an adjustable wall lamp with two joints on the arm and a rotating wall fixing. Also available in the Mini version with reduced dimensions. Spun aluminum diffuser. Available with matt grey, whitewash or black body, with white internal diffusers. Direct and indirect lighting output. Double switch on the cable, for a functional and adjustable light output.



## E26 FLUO/LED/HALO

### LAMPING

Source	E26 Ø4.3" ( DOWN ) + A60 ( UP )
Total power	2 X 70W
Emission	DOUBLE EMISSION, DIRECT + INDIRECT
Switching	switch on cable, mono switch
Tension	120V
IP class	20
Dimensions	Ø 19.7" x 31.5" H
Materials	aluminum + steel
Notes	cable length 4.9'+4.2'
Accessories	Lipari ring,
Net lamp weight	11 lbs

### Codes

LDM EWW 31  
LDM EDD 31  
LDM ENN 31

### Structure/Diffuser

whitewash/whitewash  
matt grey/grey / whitewash  
black/whitewash

### PACKAGE

Package 01

Dimension: 61.8" x 35" x 8.7" inches / Gross weight: 19,8 lbs

### Certificazioni

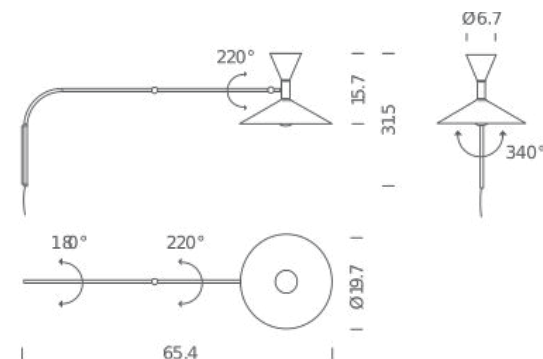

# LAMPE DE MARSEILLE MINI

*Le Corbusier*

Mini version of the Lampe de Marseille.

Aluminum with spun aluminum diffuser.

Available with matt grey, whitewash or black body, with white internal diffusers.

Direct and indirect lighting output.

Switch on the cable. Wall installation also without plug. Functional and adjustable light output



## E12 FLUO/LED/HALO

### LAMPING

Source	E12 P45
Total power	2 X 46W
Emission	DOUBLE EMISSION, DIRECT + INDIRECT
Switching	switch on cable, mono switch
Tension	120V
IP class	20
Dimensions	Ø 11.8" x 19.7" H
Materials	aluminum + steel
Notes	installation with plug cable length 1.3m+3.9m, orientable, *grey matt RAL 7046, whitewash RAL 9002
Accessories	Lipari ring,
Net lamp weight	2,9 lbs

### Codes

LMM EWW 31  
LMM EDD 31  
LMM ENN 31

### Structure/Diffuser

whitewash/whitewash  
matt grey/grey / whitewash  
black/whitewash

### PACKAGE

Package 01

Dimension: 16.5" x 31.5" x 4.7" inches / Gross weight: 4,9 lbs

### Certificazioni

