

ALA

FERRUCCIO LAVIANI



A combination of creativity and expert craftsmanship, the **Ala** table is the dominant presence in the living room – the setting for the day-to-day goings-on of domestic life. The round or semi-oval table top, outlined by a border that takes the edge off the thickness, appears suspended in mid-air, almost ready to take flight. The tapered legs only heighten this effect, based on the design of the wings of an aeroplane.

TYPE / TABLES

TECHNICAL DESCRIPTION

*A new platform enriches the **Ala** table collection, 3100 mm in length. Tables with wooden base veneered or matt lacquered. Moulded top available in two versions: oval top available in marble top in all variants or in transparent glass; round top available in moulded marble and undertop in moulded wood same finish as the base. For round top available an optional revolving moulded top in marble (Lazy Susan), is available in two dimensions.*

MisuraEmme®

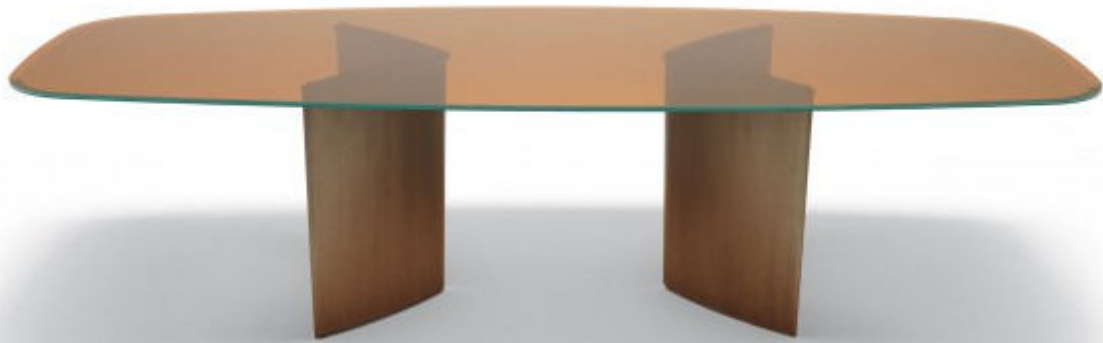

DESIGNER

FERRUCCIO LAVIANI

Born in Cremona in 1960 Laviani attends the Istituto Professionale Internazionale per l'Artigianato Liutario e del Legno di Cremona, receiving his degree in 1978. He later attends the Faculty of Architecture, at the Politecnico di Milano where he graduates in 1986, while attending at the same time the Scuola Politecnica di Design in Milan from 1982 to 1984. In 1983 he starts working for Michele De Lucchi; he becomes a partner in 1986 and works there until 1991, when he decides to open his own studio in Milan. Laviani's work mainly focuses on product design, interior design, art direction and graphic. Since 1991, he is the Art Director for Kartell; same role he has played for other companies. He designs retail spaces and set-ups, offices and houses for private clients, as well as for furniture and fashion. In 2008 an exhibition was dedicated to the lamps he designed for Kartell. Bourgie and Take lamps for Kartell are part of the permanent Collection of IMA, *Indianapolis Museum of Art (USA)*; also other products have been featured in museums and shows all over the world. In 2015, Laviani develops the new concept for Kartell Museum in Noviglio, updating the interior design he had conceived in 1999, when he received the award Premio Guggenheim Impresa & Cultura 2000, as the best museum of a company. Last year, he has started a collaboration with the Italian mosaic brand Bisazza. In 2016 Ferruccio has designed the pop-up store for the fashion designer Paula Cademartori and the set-up for the Haute Couture Women show for Dolce e Gabbana, at Laboratori Ansaldo, Teatro alla Scala, Milan.



TOP FINISHINGS

MATT LACQUERED



01 Gesso

8B Caolino

9G Ostrica

6B Grigio
Pietra

14 Nero

02 Talco

9F Sand

4G Argilla

8C
Cappuccino5B Grigio
Lava

72 Sabbia

8A Beige

9T Toffee

93 Melange

13 Sepia

09 Wengè



81 Fuoco

94 Marsala

95 Ruggine

8S Giallo

9B Senape

98 Oliva

9H Petrolio

9E Deep Blu

TRANSPARENT GLASS

V00
Naturale

V05 Fumé

MARBLES

BC Bianco
Carrara MattCA Calacatta
Oro MattEM
Emperador
MattTV
Travertino
MattBA Basaltite
MattGT Grey
Stone GlossyMR
Marquinia
GlossySR Sahara
Noir Glossy

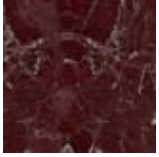

RL Rosso
Lepanto
Glossy



OR Orobico
Glossy

BASE / UNDERTOP FINISHINGS

MATT LACQUERED



MATT VENEERS

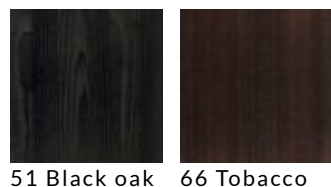

DIMENSIONS

Semi-oval table with glass top

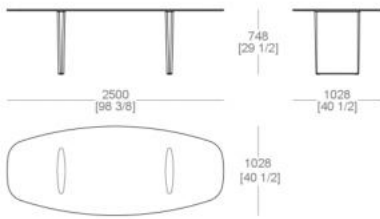

Semi-oval table with marble top

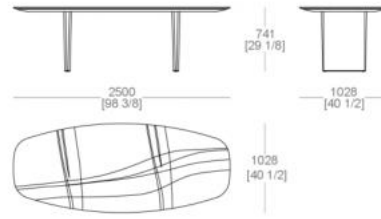

Semi-oval table with glass top

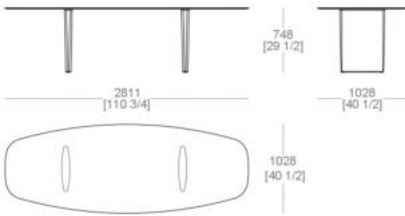

Semi-oval small table with marble top

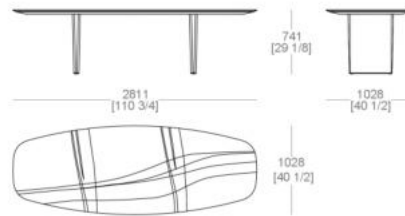

Semi-oval small table with glass top

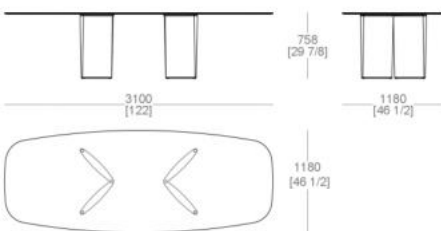

Round table with marble top

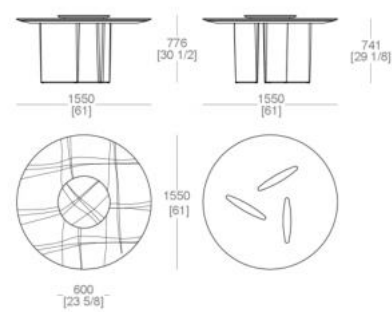

Round table with marble top

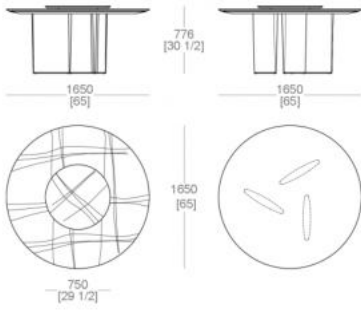

Round table with marble top

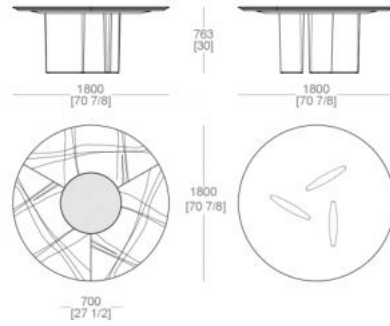

Round table with marble top

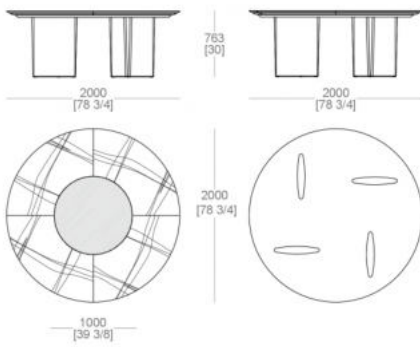

Round table with marble top

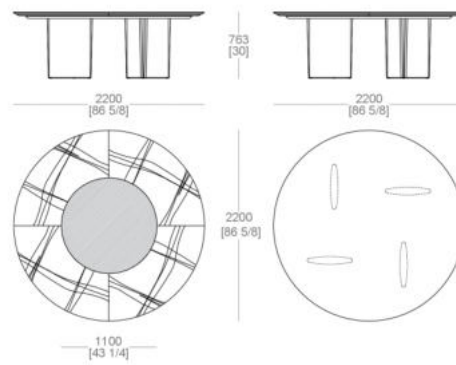

Round table with marble top

