

WTR860WPM PWash&TDos 8/5kg

WT1 washer-dryer:

with TwinDos and QuickPower – ready-to-wear clothes at the touch of a button.



- Automatic detergent dispensing at the touch of a button – TwinDos
- Washing and drying in the shortest of times – QuickPower
- Your favourite items are ready in < 1 hour – Single Wash&Dry
- M Touch – the appliance is controlled by tapping or swiping
- Miele@home – clever networking opens up new possibilities*

* Additional digital offer from Miele & Cie. KG. All smart applications are made possible with the Miele@home system. The range of functions can vary depending on the model and the country.



EAN: 4002516371021 / Material number: 11576550 / Old Material Number: 11TR8604GB

Construction type	
Suitable for stacking	•
Side-by-side	•
Slot-in	•
Can be built-under	•
Door hinge	right
Model	
Front-loader	•
Washing machine with dryer function	
Continuous washing and drying cycle	•
Electronic residual moisture sensing	•
Condenser dryers with water cooling	•
Thermospin	•
Spinning	
Max. spin speed	1600
Rinse hold	•
Without spin function	•
Design	
Appliance colour	Lotus white
Control panel colour	Lotus white
Door design	Chrome
Control panel version	Straight
Control type	Touch controls
Display	MTouch
Cleaning performance	
Innovative PowerWash technology	•
PowerWash	•
TwinDos automatic detergent dispensing	•
CapDosing portioned dispensing	•
Stains option	•
Certified virus hygiene	•
Gentle laundry care	
Honeycomb drum	•
Load in kg when washing	8.0
Load in kg when drying	5.0
PerfectCare technology	•
User convenience	
Networking with Miele@home	•
SteamCare steam system	•
Delay start up to 24 hours	•
Time left display	•
Time of day display	•
Programme sequence indicator	in display
Automatic rinse out fluff	•
Drum lighting	LED
MultiLingua	•
AutoClean detergent drawer	•
AddLoad	•
Efficiency and sustainability	
Energy efficiency class (A–G)	A

WTR860WPM PWash&TDos 8/5kg

WT1 washer-dryer:

with TwinDos and QuickPower – ready-to-wear clothes at the touch of a button.



EAN: 4002516371021 / Material number: 11576550 / Old Material Number: 11TR8604GB

Energy efficiency class for washing and drying (A–G)	D
Energy consumption in kWh in the Cottons 60° standard programme with a full load and subsequent Normal dry cycle	5.47
Weighted energy consumption per 100 operating cycles for the complete operating cycle in kWh	262
Weighted energy consumption per 100 operating cycles for the wash cycle in kWh	46
Weighted water consumption per operating cycle for the wash cycle in l	47
Weighted water consumption per operating cycle for the complete operating cycle in l	68
Acoustic airborne noise emission class (spin cycle)	A
Programme running time at nominal capacity for the wash cycle	219
Programme running time at nominal capacity for the complete operating cycle	389
Power rating in off mode in W	0.10
Power rating in networked standby in W	0.50
Low temperature wash "Cold" and "20 °C"	•
Flow meter	•
Foam sensing	•
ProfiEco motor	•
Wash programmes	
QuickPower	•
Automatic	•
Cottons (coloureds)	•
Minimum iron	•
Shirts	•
Silk (hand-washable)	•
Woollens (hand-washable)	•
Express	•
Dark garments	•
Denim	•
Outerwear	•
Proofing	•
Sportswear	•
Trainers	•
Pillows	•
Down	•
Curtains	•
Cottons hygiene	•
Clean machine	•
Cottons Arrow	•
First wash	•
Starch	•
ECO 40-60	•
Drying programmes	
QuickPower	•
Automatic	•
Cottons (coloureds)	•
Minimum iron	•

WTR860WPM PWash&TDos 8/5kg

WT1 washer-dryer:

with TwinDos and QuickPower – ready-to-wear clothes at the touch of a button.

EAN: 4002516371021 / Material number: 11576550 / Old Material Number: 11TR8604GB

Delicates	•
Shirts	•
Silk	•
Woollens	•
Express	•
Dark garments	•
Denim	•
Outerwear	•
Proofing	•
Sportswear	•
Trainers	•
Standard pillows	•
Cottons hygiene	•
First wash	•
Cool air	•
Warm air	•
Freshen up	•
Steam care	•
Extras	
Anti-crease	•
Short	•
Soak	•
Pre-wash	•
Water plus	•
Additional rinse cycle	•
Buzzer	•
AllergoWash	•
Quality	
Suds container	Stainless Steel
Counterweights made of cast iron	•
Safety	
PIN-Code	•
Optical interface	•
Technical data	
Dimensions in mm (width)	596
Dimensions in mm (height)	850
Dimensions in mm (depth)	637
Appliance depth in mm with opened door	1055
Weight in kg	98
Total rated load in kW	2.10-2.40
Voltage in V	220-240
Fuse rating in A	13
Frequency in Hz	50
Length of supply lead in m	2
Accessories supplied	
3 Caps	•
UltraPhase 1 + 2	•
Voucher for 5 Miele UltraPhase cartridges	•

WTR860WPM PWash&TDos 8/5kg

WT1 washer-dryer:

with TwinDos and QuickPower – ready-to-wear clothes at the touch of a button.



EAN: 4002516371021 / Material number: 11576550 / Old Material Number: 11TR8604GB

Available display languages

Available display languages through MultiLingua

bahasa malaysia, dansk,
deutsch, english (AU),
english (CA), english (GB),
english (US), español,
français (CA), français
(FR), hrvatski, italiano,
magyar, nederlands,
norsk, polski, português,
русский, română,
slovenčina, slovenščina,
srpski, suomi, svenska,
türkçe, українська, čeština,
ελληνικά,

WTR860WPM PWash&TDos 8/5kg

WT1 washer-dryer:

with TwinDos and QuickPower – ready-to-wear clothes at the touch of a button.

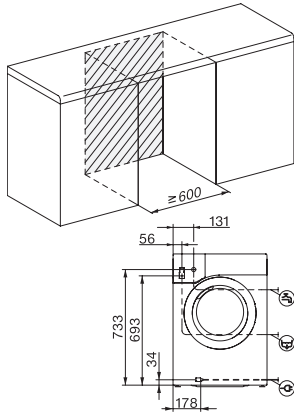

WT1 8/5 kg, installation drawing, slanted facia, straight facia, measures in mm

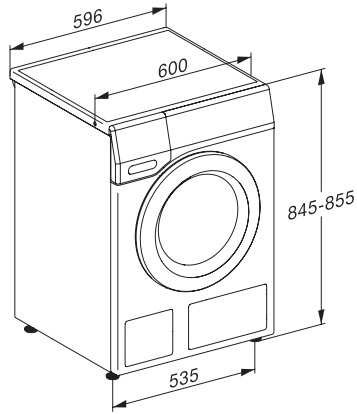

WT1 8/5 kg, drawing, slanted facia, straight facia, measures in mm

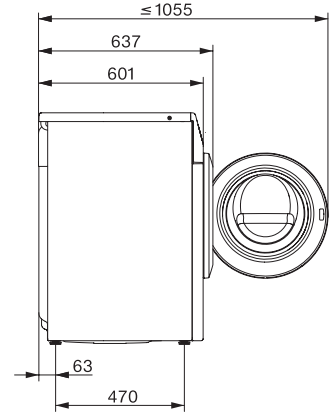

WT1 8/5 kg, drawing, slanted facia, straight facia, measures in mm

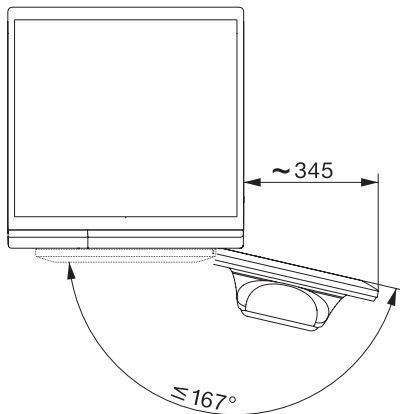

WT1 8/5 kg, drawing, slanted facia, straight facia, measures in mm