

TEF765WP EcoSpeed&8kg
T1 heat-pump dryer:
with A+++ and DryCare 40 for efficient yet gentle drying.



- DryCare 40 – dries almost anything that can be washed at 40 °C
- Faster drying combined with maximum energy efficiency – EcoSpeed
- Quickly switch between 2 favourite fragrances – FragranceDos²
- Savings for the life of your tumble dryer – EcoDry technology
- Miele@home – clever networking opens up new possibilities*

* Additional digital offer from Miele & Cie. KG. All smart applications are made possible with the Miele@home system. The range of functions can vary depending on the model and the country.

A+++

EAN: 4002516476245 / Material number: 11871820 / Old Material Number: 12EF7652GB

Construction type	
Suitable for stacking	•
Side-by-side	•
Slot-in	•
Can be built-under	•
Door hinge	left
Model	
Product brand	T1 Chrome Edition
Heat pump dryer	•
Design	
Appliance colour	Lotus white
Control panel colour	Lotus white
Rotary selector colour	Lotus White / Chrome ring
Control panel version	Straight
Control type	Rotary selector
Display	DirectSensor white, 7 segment
Drying results	
PerfectDry precision drying	•
FragranceDos ² fragrance system	•
Intelligent drum reversal	•
Proven hygiene	•
Gentle laundry care	
Honeycomb drum	•
Load in kg	8.0
User convenience	
Networking with Miele@home	•
Wash2Dry	•
Delay start up to 24 hours	•
Time left display	•
Programme sequence indicator	No
Drum lighting	LED
Condensate container	•
Integrated condensed water drainage	•
AddLoad	•
Efficiency and sustainability	
Energy efficiency class (A+++ – D)	A+++
Annual energy consumption in kWh	161
Duration in minutes in the standard programme	165
Noise in the Cottons programme with full load in db(A) re 1 pW	66
Condensation efficiency class	A
Energy consumption in kWh in the Cottons Normal dry standard programme with a full load	1.32
EcoDry technology	•
Maintenance-free heat exchanger	•
ProfiEco motor	•
EcoSpeed	•
Drying programmes	
Cottons (coloureds)	•
Minimum iron	•

TEF765WP EcoSpeed&8kg
T1 heat-pump dryer:
with A+++ and DryCare 40 for efficient yet gentle drying.



EAN: 4002516476245 / Material number: 11871820 / Old Material Number: 12EF7652GB

Delicates	•
Shirts	•
Woollens handcare	•
Express	•
Proofing	•
Bed linen	•
Warm air/DryFresh	•
Extras	
Anti-crease	•
Buzzer	•
DryCare 40	•
Quality	
Soft ribs	•
Safety	
PIN-Code	•
Empty out container indicator	•
Clean filter indication	•
Optical interface	•
Technical data	
Dimensions in mm (width)	596
Dimensions in mm (height)	850
Dimensions in mm (depth)	636
Appliance depth in mm with opened door	1054
Weight in kg	56
Total rated load in kW	1.10
Voltage in V	220-240
Fuse rating in A	13
Frequency in Hz	50
Length of supply lead in m	2.0
Hermetically sealed	•
Type of coolant	R290
Refrigerant quantity in kg	0.14
Refrigerant global warming potential	3
Appliance global warming potential	0.42
Replacing lamps	Customer Service
Accessories supplied	
Fragrance flacon	•
Voucher for a second fragrance flacon	•

TEF765WP EcoSpeed&8kg

T1 heat-pump dryer:

with A+++ and DryCare 40 for efficient yet gentle drying.



T1 installation drawing, slanted facia, straight facia, measures in mm

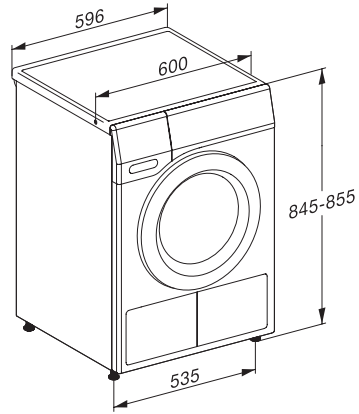

T1 drawing, slanted facia, straight facia, measures in mm

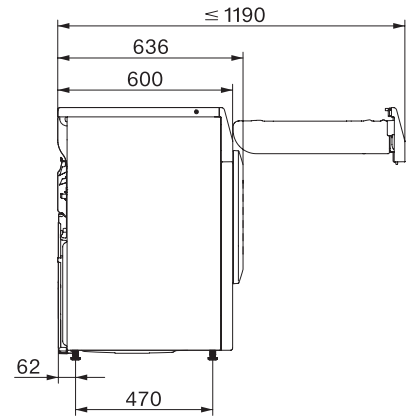

T1 drawing, slanted facia, straight facia, with porthole, measures in mm



T1 drawing, slanted facia, straight facia, measures in mm