

DAD 4840 Black Levantar
Downdraft extractor system
in elegant matt black design and with intuitive SmartControl operation



- 916 mm wide – the perfect combination with panorama hobs
- Easy recirculation mode installation with plug&play accessory set
- Motorised retractable deflector plate – Hood in Motion
- Unique user convenience – Con@ctivity
- Efficient filtration- 10-ply stainless-steel grease filter

A

EAN: 4002516538981 / Material number: 11875820 / Old Material Number: 28D4840MGB

Construction type	
Downdraft extractor system	•
Operating modes	
Type of air guide	Convertible
Design	
Colour	Matt black
Edge extraction	•
User convenience	
Miele@home	•
Automatic function Con@ctivity 3.0 (WiFi)	•
Electronic controls	•
Touch-on-glass controls	•
Run-on time 5/15 min.	•
Programmable Booster level switch-off	•
Grease filter saturation indicator	•
Grease filter saturation indicator programmable	•
Active charcoal filter saturation indicator programmable	•
Motor-operated cooker hoods	•
Efficiency and sustainability	
Energy efficiency class (A+++ to D)	A
Annual energy consumption in kWh/year	41.6
Fluid dynamic efficiency class	A
Lighting efficiency class	A
Grease filtering efficiency class	B
ECO motor	•
PowerManagement system	•
Cleaning convenience	
Easy-to-clean canopy interior – CleanCover	•
Filter system	
Number of dishwasher-safe stainless steel grease filters (10-ply)	2
Lighting	
LED	•
Number x W	1 x 11,2 W
Light intensity in lx	400 lx
Colour temperature in K	3500 Kelvin
Dimmer function	•
Blower	
Dual-action blower	•
DC motor	•
Extraction	
Air throughput in Level 1 (m ³ /h) according to EN 61591	200
Air throughput in Level 2 (m ³ /h) according to EN 61591	340
Air throughput in Intensive level (m ³ /h) according to EN 61591	600
Air throughput in Level 3 (m ³ /h) according to EN 61591	440
Air throughput in Booster level (m ³ /h) according to EN 61591	640
Sound power in Level 1 (dB(A) re 1 pW) according to EN 60704-3	44.0

DAD 4840 Black Levantar
Downdraft extractor system
in elegant matt black design and with intuitive SmartControl operation



EAN: 4002516538981 / Material number: 11875820 / Old Material Number: 28D4840MGB

Sound power in Level 2 (dB(A) re 1 pW) according to EN 60704-3	57.0
Sound power in Level 3 (dB(A) re 1 pW) according to EN 60704-3	62.0
Sound power in Booster level (dB(A) re 1 pW) acc. to EN 60704-3	70.0
Sound power in Booster level (dB(A) re 1 pW) acc. to EN 60704-3	72.0
Sound pressure in Level 1 (dB(A) re 20 µPa) according to EN 60704-2-13	30.0
Sound pressure in Level 2 (dB(A) re 20 µPa) according to EN 60704-2-13	43.0
Sound pressure in Level 3 (dB(A) re 20 µPa) according to EN 60704-2-13	49.0
Sound pressure in Booster level (dB(A) re 20 µPa) acc. to EN 60704-2-13	56.0
Sound pressure in Booster level (dB(A) re 20 µPa) acc. to EN 60704-2-13	58.0
Recirculation	
Air throughput in Level 1 (m³/h) according to EN 61591	160
Air throughput in Level 2 (m³/h) according to EN 61591	320
Air throughput in Level 3 (m³/h) according to EN 61591	415
Air throughput in Booster level (m³/h) according to EN 61591	520
Air throughput in Booster level (m³/h) according to EN 61591	555
Sound power in Level 1 (dB(A) re 1 pW) according to EN 60704-3	50.0
Sound power in Level 2 (dB(A) re 1 pW) according to EN 60704-3	64.0
Sound power in Level 3 (dB(A) re 1 pW) according to EN 60704-3	69.0
Sound power in Booster level (dB(A) re 1 pW) acc. to EN 60704-3	75.0
Sound power in Booster level (dB(A) re 1 pW) acc. to EN 60704-3	76.0
Sound pressure in Level 1 (dB(A) re 20 µPa) according to EN 60704-2-13	37.0
Sound pressure in Level 2 (dB(A) re 20 µPa) according to EN 60704-2-13	50.0
Sound pressure in Level 3 (dB(A) re 20 µPa) according to EN 60704-2-13	56.0
Sound power in Booster level (dB(A) re 20 µPa) acc. to EN 60704-2-13	61.0
Sound pressure in Booster level (dB(A) re 20 µPa) acc. to EN 60704-2-13	62.0
Safety	
Safety switch-off	•
Single-ply safety glass (ESG)	•
Technical data	
Canopy width in mm	916
Canopy depth in mm	170
Net weight in kg	34.0
Length of supply lead in m	1.5

DAD 4840 Black Levantar
Downdraft extractor system
in elegant matt black design and with intuitive SmartControl operation



EAN: 4002516538981 / Material number: 11875820 / Old Material Number: 28D4840MGB

Standard plug fitted	•
Total rated load in kW	0.25
Voltage in V	230
Fuse rating in A	10
Frequency in Hz	50
Number of phases	1
Installation notes	
Diameter of exhaust duct in mm	150
Optimal combination with hob	KM 7684 FL; KM 7689 FL
Combination with WiFi-enabled Miele hob	recommended
Optional accessories	
Active charcoal filter	Nein

DAD 4840 Black Levantar
Downdraft extractor system
in elegant matt black design and with intuitive SmartControl operation

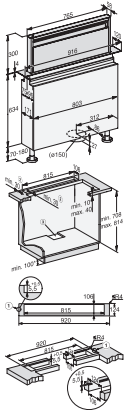

DAD4840, Installation drawings

1. Stepped cutout for flush-fit installation in stone worktops (granite, marble), 2. Ensure that materials are sufficiently stable, 3. Cut-out off-centre., Exhaust duct \varnothing 150 mm., * Only required when flat ducting is laid under cabinets or the DUU 600 recirculation box is used.

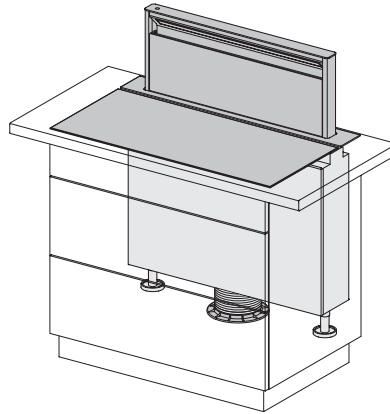

DAD4840, DAD4940 - DUP150, Installation version 1, Installation drawings

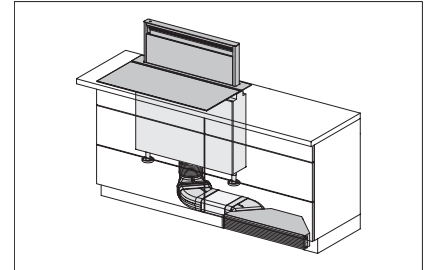

DAD4840, DAD4940 - DUU600 Plinth box, Installation version 2, Installation drawings

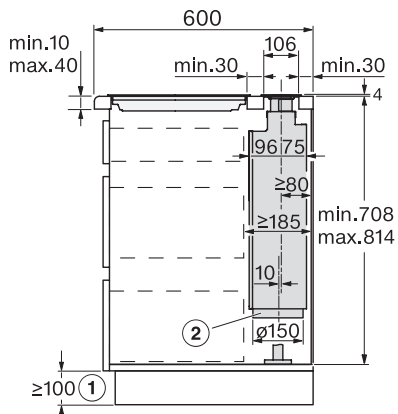

DAD4840, DAD4940, overlying – AP600 mm, Side view, Installation drawings

Only required when flat ducting is laid under cabinets or the DUU 600 recirculation box is used., Exhaust duct \varnothing 150 mm.

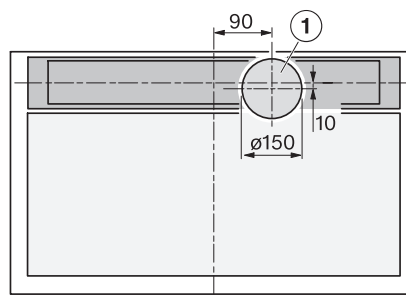

DAD4840, DAD4940, flush – AP600 mm, Top view, Installation drawings

Exhaust duct \varnothing 150 mm.

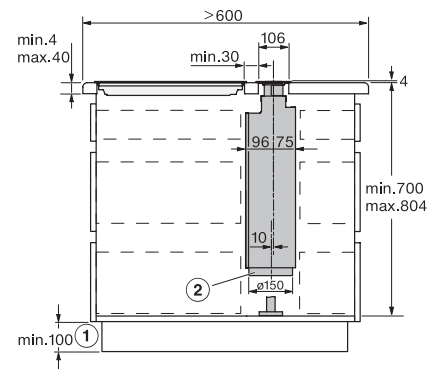

DAD4840, DAD4940, overlying AP > 600 mm, Side view, Installation drawings

Only required when flat ducting is laid under cabinets or the DUU 600 recirculation box is used., Exhaust duct \varnothing 150 mm.

DAD 4840 Black Levantar Downdraft extractor system in elegant matt black design and with intuitive SmartControl operation

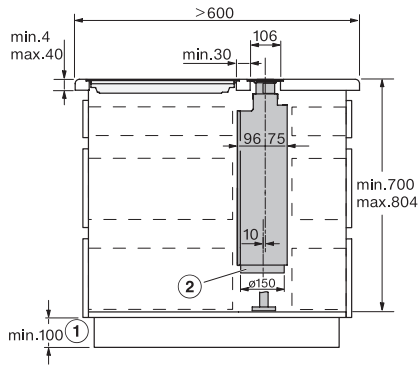

DAD4840, DAD4940, flush AP > 600 mm, Side view, Installation drawings

Only required when flat ducting is laid under cabinets or the DUU 600 recirculation box is used., Exhaust duct Ø 150 mm.

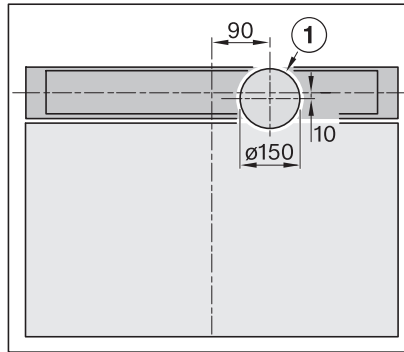

DAD4840, DAD4940, flush AP > 600 mm, Top view, Installation drawings

Exhaust duct Ø 150 mm.

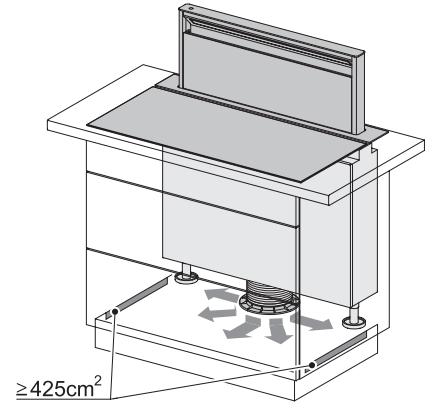

DAD4840, DAD4940 - DUP150, Installation version 1, Installation drawings

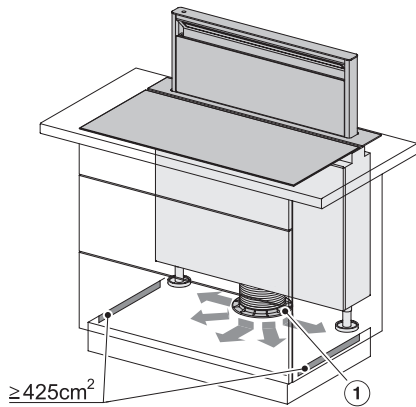

DAD4840, DAD4940 - DUP150, Installation version 1, Installation drawings

DUP 150

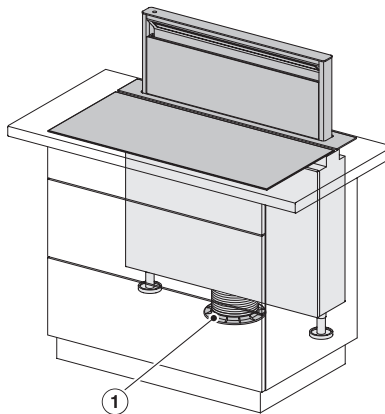

DAD4840, DAD4940 - DUP150, Installation version 1, Installation drawings

DUP 150

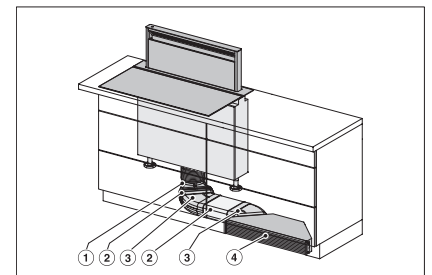

DAD4840, DAD4940 - DUU 600 Plinth box, Installation version 2, Installation drawings

DFK-AK 90, DFK-R 1000, DFK-BH-45, DUU 600

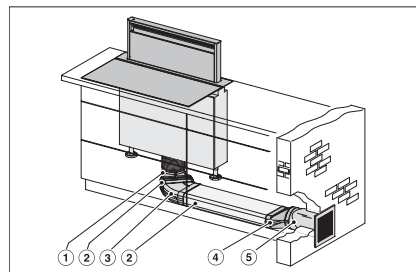

DAD4840, DAD4940 - DMK150-1 wall box, Installation version 3, Installation drawings

DFK-AK 90, DFK-R 1000, DFK-BH 45, DFK-A, DMK 150-1

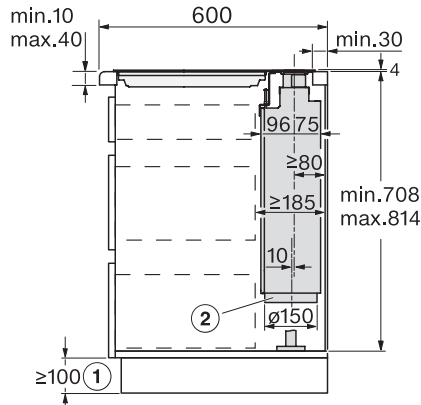

DAD4840, DAD4940 - surface mounted - side view - Installation drawings

Only required if flat ducts are laid under the cabinets or the DUU 600 recirculation box is used., Exhaust air connection Ø 150 millimetres.

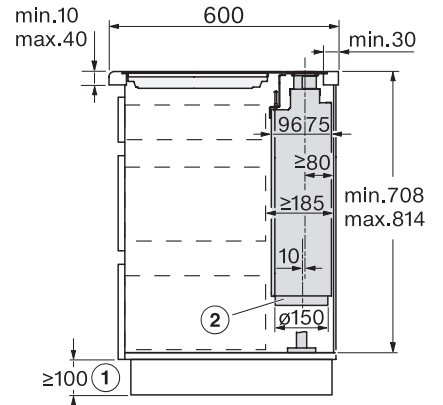

DAD4840, DAD4940 - flush - side view - Installation drawings

Only required if flat ducts are laid under the cabinets or the DUU 600 recirculation box is used., Exhaust air connection Ø 150 millimetres.

DAD 4840 Black Levantar Downdraft extractor system in elegant matt black design and with intuitive SmartControl operation

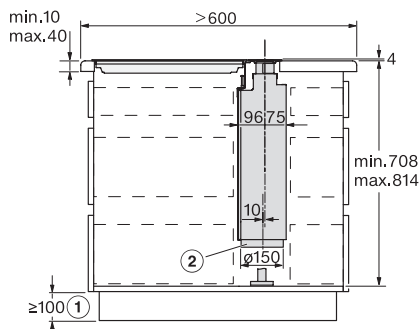

DAD4840, DAD4940 - surface mounted, AP > 600 mm - side view - Installation drawings

Only required if flat ducts are laid under the cabinets or the DUU 600 recirculation box is used., Exhaust air connection \varnothing 150 millimetres.

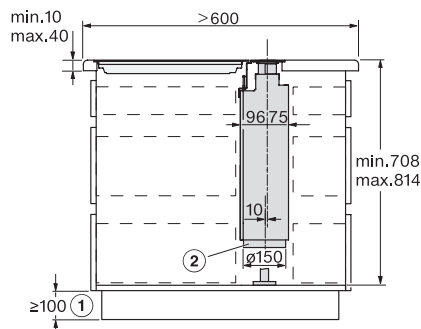

DAD4840, DAD4940 - flush - side view - Installation drawings

Only required if flat ducts are laid under the cabinets or the DUU 600 recirculation box is used., Exhaust air connection \varnothing 150 millimetres.

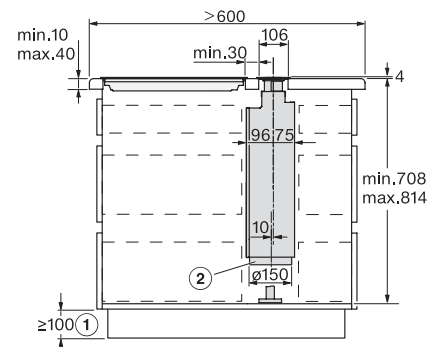

DAD4840, DAD4940 - surface mounted, AP > 600 mm - side view - Installation drawings

Only required if flat ducts are laid under the cabinets or the DUU 600 recirculation box is used., Exhaust air connection \varnothing 150 millimetres.

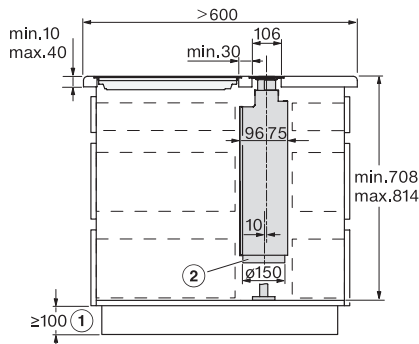

DAD4840, DAD4940 - flush - side view - Installation drawings

Only required if flat ducts are laid under the cabinets or the DUU 600 recirculation box is used., Exhaust air connection \varnothing 150 millimetres.

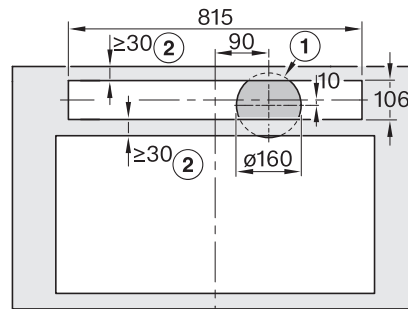

DAD4840, DAD4940, overlying, Installation drawings

1) Cut-out for exhaust air duct in the cabinet base., 2) Ensure sufficient stability of the worktop.

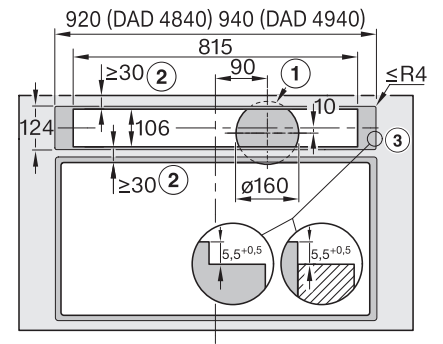

DAD4840, DAD4940, flush, Installation drawings

1) Cut-out for exhaust air duct in the cabinet base., 2) Ensure sufficient stability of the worktop., 3) Step milling for flush mounting in a worktop. Note the, the different milling widths for the hob and the downdraft. Instead of a, a 5.5 mm downwardly offset wooden strip can be, can be installed (not included in the scope of delivery) , Exhaust air connection \varnothing 150 mm.

DAD 4840 Black Levantar
Downdraft extractor system
in elegant matt black design and with intuitive SmartControl operation

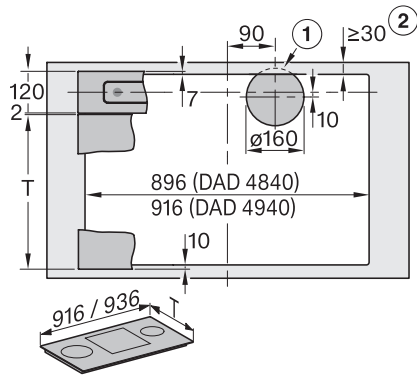

DAD4840, DAD4940, overlying, Installation drawings

1) Cut-out for exhaust air duct in the cabinet base., 2) Ensure sufficient stability of the worktop.

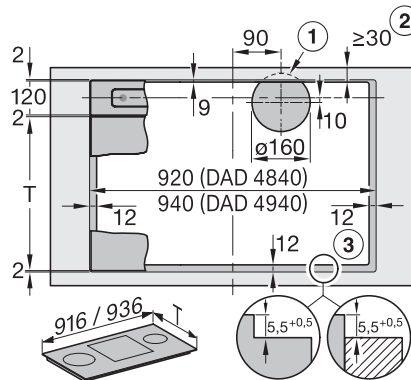

DAD4840, DAD4940, flush, Installation drawings

1) Cut-out for exhaust air duct in the cabinet base., 2) Ensure sufficient stability of the worktop., 3) Step milling for flush mounting in a worktop. Note the, the different milling widths for the hob and the downdraft. Instead of a, Instead of a step milling, a 5.5 mm downwardly offset wooden strip can be, can be installed (not included in the scope of delivery).. , Exhaust air connection \varnothing 150 mm.

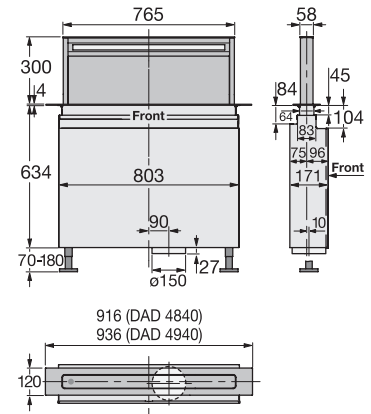

DAD4840, DAD4940, Installation drawings