

HEATHFIELD & CO

PRODUCT SPECIFICATION SHEET

Wall Light | TORCHERE NICKEL

WALL LIGHT

Material: Metal
Finish shown: Nickel
Code: WL-TORC-PLNL

LAMPSHADE AS SHOWN

12" Crescent Ivory Satin
Shade code: SH-12-CRES
Shade lining: Gold PVC

SWITCHING & PLUG

Hardwired

WEIGHT

1.1 kg approx.

LAMPING

1 x E27 Lampholder - 40W max. LED bulb recommended.

FIXING NOTE

It is the buyer's responsibility to ensure that suitable fixings are used.

WARRANTY

12 Months

FINISHING NOTE

All metalwork is handcrafted and may vary from piece to piece with slight variation in finish and detailing.

CLEANING INSTRUCTIONS

The finishes on this luminaire only require regular cleaning with a soft dry duster. Abrasive or chemical cleaners may harm the finish and should not be used. Shade to be dusted with a clean dry cloth.

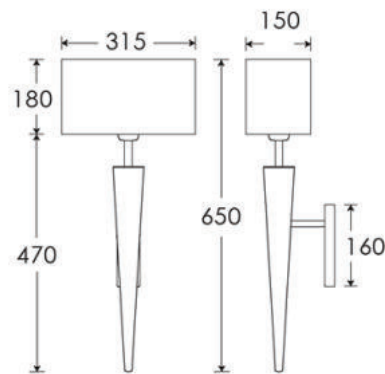

Dimensions in mm and approximate

H&CO

Decorative lighting
for beautiful spaces

www.heathfield.co.uk | + 44 (0) 1732 350450 | sales@heathfield.co.uk

Unit 1, Priory Road, Tonbridge, Kent, TN9 2AF, United Kingdom

HEATHFIELD & CO

PRODUCT SPECIFICATION SHEET

Wall Light | TORCHERE ANTIQUE BRASS

WALL LIGHT

Material: Metal
Finish shown: Antique Brass
Code: WL-TORC-ABRS

LAMPSHADE AS SHOWN

12" Crescent Black Satin
Shade code: SH-12-CRES
Shade lining: Gold PVC

SWITCHING & PLUG

Hardwired

WEIGHT

1.1 kg approx.

LAMPING

1 x E27 Lampholder - 40W max. LED bulb recommended.

FIXING NOTE

It is the buyer's responsibility to ensure that suitable fixings are used.

WARRANTY

12 Months

FINISHING NOTE

All metalwork is handcrafted and may vary from piece to piece with slight variation in finish and detailing.

CLEANING INSTRUCTIONS

The finishes on this luminaire only require regular cleaning with a soft dry duster. Abrasive or chemical cleaners may harm the finish and should not be used. Shade to be dusted with a clean dry cloth.

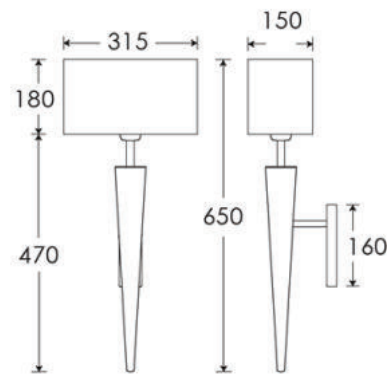

Dimensions in mm and approximate

H&CO

Decorative lighting
for beautiful spaces

www.heathfield.co.uk | +44 (0) 1732 350450 | sales@heathfield.co.uk

Unit 1, Priory Road, Tonbridge, Kent, TN9 2AF, United Kingdom