



## Musa

Cod.ACC.800.MUS  
Design RedCreative  
Production year 2021

Bookcase with tubular metal structure with rectangular section and covered in leather. Crystal shelves and details in brass or lacquered in various colors.

### Structure options

- CPF** - Full grain leather (30 colors)
- CTT** - Contract leather (15 colors)

### Shelves options

- VBR** - Bronze crystal glass
- VEF** - Fumé crystal glass
- VET** - Transparent crystal glass

### Shelf bracket and feet

- OS** - Satin brass
- OB** - Bronzed brass
- NO** - Matt black
- GF** - Graphite painted
- BO** - Matt white
- BR** - Bronze painted

To check the available colors, consult the finishing catalogue.

## Technical information

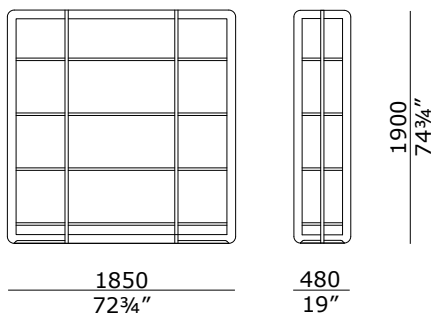

All measurements in **millimetres** and **inches**



## Musa

Cod.ACC.800.MUS  
Design RedCreative  
Anno di produzione 2021

Libreria con struttura in tubolare metallico a sezione rettangolare e rivestito in cuoio. Mensole in cristallo e dettagli in ottone o metallo verniciato.

Rivestimento struttura

**CPF** - Cuoio pieno fiore (30 colori)

**CTT** - Cuoio contract (15 colori)

Opzioni vetro per mensole

**VBR** - Cristallo bronzato

**VEF** - Cristallo fumé

**VET** - Cristallo trasparente

Opzioni reggimensola e piedini

**OS** - Ottone satinato

**OB** - Ottone bronzato

**NO** - Nero opaco

**BO** - Bianco opaco

**GF** - Verniciato grafite

**BR** - Verniciato bronzo

Per verificare i colori disponibili consultare la scheda finiture.

## Info tecniche

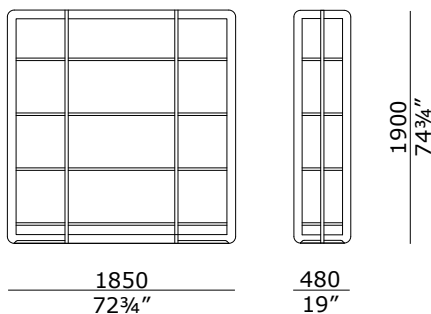

Le misure riportate sono in  
**millimetri e inches.**