

Ledermann counter stool light

Cod.10.0606
Design Tom Kelley
Production year 2018

Ledermann counter stool has a wooden frame with 4 legs, in tubular conical shape. Seat and back are covered with leather. Seat with bottom in sheet metal covered with black technical fabric. Back can be completely covered, joining to the seat or just with a leather strap in "light" version.

Structure materials available

FG - Grey ash
FS - Bleached ash
FR - Natural ash

Covering materials available

CPF - Full grain leather (30 colors)
CTT - Contract leather (15 colors)

To check the available colors, consult the finishing catalogue.



Technical information

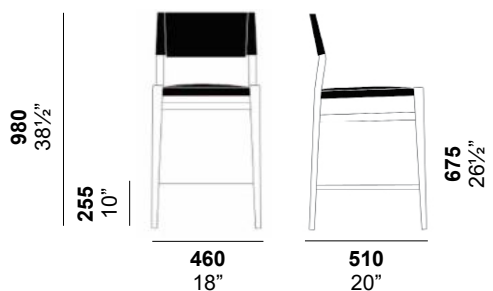

Dimensions
57 x 60 x 102 cm
22 1/2 x 23 3/4 x 40 inches

Type Carton



Net weight 5.5 kg/ 12 lb
Gross weight 7.5 kg/ 16.5 lb



Volume 0.348 m³

All measurements in
millimetres and inches

Design

Tom Kelley



Born in East-Germany, after political problems and Stasi-Prison he studies in Aachen, Munich and then in Long Beach (California). Initially both painter and designer, brought by his work and studies to Italy, where he lives more or less since 20 years in Venice. He worked for many companies in several countries. Looking always for simplicity, he sees himself as primarily an observer, and believes that after a while all its observations become shapes, colors, projects and words. In these last recent years, in addition to the prominent work as designer, he restored private houses, including the famous Villa of Michael Thonet.

Ledermann sgabello counter light

Cod.10.0606
Design Tom Kelley
Anno di produzione 2018

Sgabello con struttura in legno a quattro gambe di forma conica, con seduta e schienale rivestiti in cuoio. Sedile con fondo in lamiera rivestita con tessuto tecnico di colore nero. Lo schienale può essere completamente rivestito oppure caratterizzato da una singola fascia nella versione "light".

Materiali di struttura disponibili

FG - Frassino grigio
FS - Frassino sbiancato
FR - Frassino naturale

Materiali di rivestimento disponibili

CPF - Cuoio pieno fiore (30 colori)
CTT - Cuoio contract (15 colori)

Per verificare i colori disponibili consultare la scheda finiture.



Info tecniche

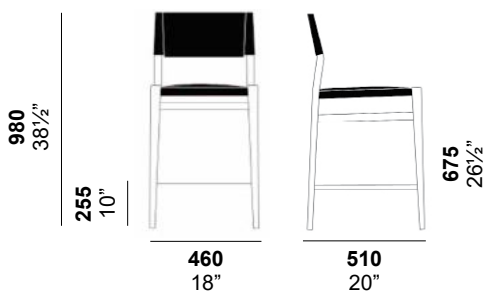

Dimensioni
57 x 60 x 102 cm
22 1/2 x 23 3/4 x 40 inches

Tipo Cartone



Peso Netto 5.5 kg/ 12 lb
Peso Lordo 7.5 kg/ 16.5 lb



Volume 0.348 m³

Le misure riportate sono in
millimetri e inches.

Design

Tom Kelley



Nato nella Germania dell'Est, dopo problemi politici e dopo essere stato rinchiuso in prigione dalla Stasi, studia ad Aquisgrana, Monaco e poi a Long Beach (California). Prima pittore e poi designer, ha portato il suo lavoro e i suoi studi in Italia, dove vive da circa 20 anni a Venezia. Ha lavorato per molte aziende in diversi paesi. Sempre alla ricerca della semplicità, si considera prima di tutto un osservatore e ritiene che dopo un po' tutte le sue osservazioni vogliono uscire fuori in forme, composizioni, colori, progetti, parole. In questi ultimi anni, oltre alla preminente attività di designer, ha restaurato case private tra cui la villa del famoso Michael Thonet.

Ledermann bar stool light

Cod.10.0607
Design Tom Kelley
Production year 2018

Ledermann bar stool has a wooden frame with 4 legs, in tubular conical shape. Seat and back are covered with leather. Seat with bottom in sheet metal covered with black technical fabric. Back can be completely covered, joining to the seat or just with a leather strap in "light" version.

Structure materials available

FG - Grey ash
FS - Bleached ash
FR - Natural ash

Covering materials available

CPF - Full grain leather (30 colors)
CTT - Contract leather (15 colors)

To check the available colors, consult the finishing catalogue.



Technical information

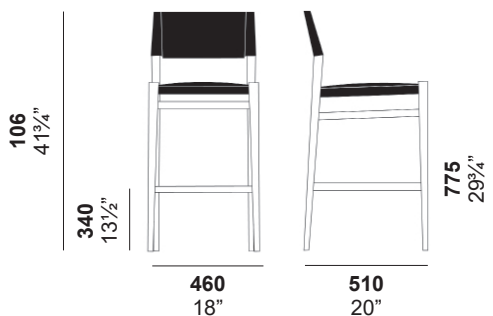

Dimensions
57 x 60 x 110 cm
22 1/2 x 23 3/4 x 43 1/4 inches

Type Carton



Net weight 6 kg/ 13.2 lb
Gross weight 8 kg/ 17 lb



Volume 0.376 m³

All measurements in
millimetres and inches

Design

Tom Kelley



Born in East-Germany, after political problems and Stasi-Prison he studies in Aachen, Munich and then in Long Beach (California). Initially both painter and designer, brought by his work and studies to Italy, where he lives more or less since 20 years in Venice. He worked for many companies in several countries. Looking always for simplicity, he sees himself as primarily an observer, and believes that after a while all its observations become shapes, colors, projects and words. In these last recent years, in addition to the prominent work as designer, he restored private houses, including the famous Villa of Michael Thonet.

Ledermann sgabello bar light

Cod.10.0607
Design Tom Kelley
Anno di produzione 2018

Sgabello con struttura in legno a quattro gambe di forma conica, con seduta e schienale rivestiti in cuoio. Sedile con fondo in lamiera rivestita con tessuto tecnico di colore nero. Lo schienale può essere completamente rivestito oppure caratterizzato da una singola fascia nella versione "light".

Materiali di struttura disponibili

FG - Frassino grigio
FS - Frassino sbiancato
FR - Frassino naturale

Materiali di rivestimento disponibili

CPF - Cuoio pieno fiore (30 colori)
CTT - Cuoio contract (15 colori)

Per verificare i colori disponibili consultare la scheda finiture.



Info tecniche

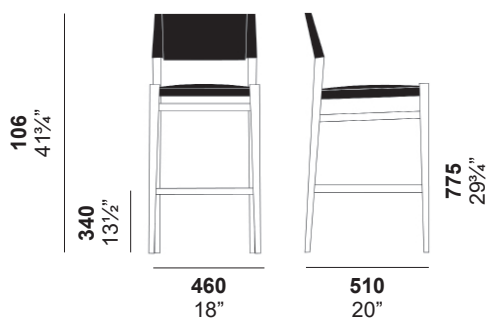

Dimensioni
57 x 60 x 110 cm
22 1/2 x 23 3/4 x 43 1/4 inches

Tipo Cartone



Peso Netto 6 kg/ 13.2 lb
Peso Lordo 8 kg/ 17 lb



Volume 0.376 m³

Le misure riportate sono in
millimetri e inches.

Design

Tom Kelley



Nato nella Germania dell'Est, dopo problemi politici e dopo essere stato rinchiuso in prigione dalla Stasi, studia ad Aquisgrana, Monaco e poi a Long Beach (California). Prima pittore e poi designer, ha portato il suo lavoro e i suoi studi in Italia, dove vive da circa 20 anni a Venezia. Ha lavorato per molte aziende in diversi paesi. Sempre alla ricerca della semplicità, si considera prima di tutto un osservatore e ritiene che dopo un po' tutte le sue osservazioni vogliono uscire fuori in forme, composizioni, colori, progetti, parole. In questi ultimi anni, oltre alla preminente attività di designer, ha restaurato case private tra cui la villa del famoso Michael Thonet.

Ledermann counter stool

Cod.10.0602
Design Tom Kelley
Production year 2018

Ledermann counter stool has a wooden frame with 4 legs, in tubular conical shape. Seat and back are covered with leather. Seat with bottom in sheet metal covered with black technical fabric. Back can be completely covered, joining to the seat or just with a leather strap in "light" version.

Structure materials available

FG - Grey ash
FS - Bleached ash
FR - Natural ash

Covering materials available

CPF - Full grain leather (30 colors)
CTT - Contract leather (15 colors)

To check the available colors, consult the finishing catalogue.



Technical information

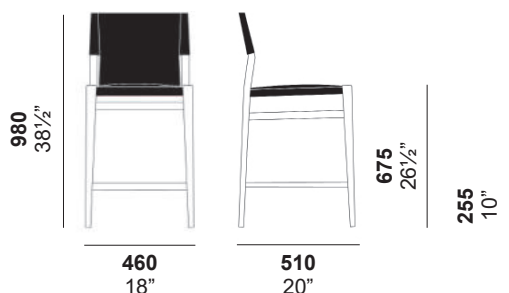

Dimensions
57 x 60 x 102 cm
22 1/2 x 23 3/4 x 40 inches

Type Carton



Net weight 5.5 kg/ 12 lb
Gross weight 7.5 kg/ 16.5 lb



Volume 0.348 m³

All measurements in
millimetres and inches

Design

Tom Kelley



Born in East-Germany, after political problems and Stasi-Prison he studies in Aachen, Munich and then in Long Beach (California). Initially both painter and designer, brought by his work and studies to Italy, where he lives more or less since 20 years in Venice. He worked for many companies in several countries. Looking always for simplicity, he sees himself as primarily an observer, and believes that after a while all its observations become shapes, colors, projects and words. In these last recent years, in addition to the prominent work as designer, he restored private houses, including the famous Villa of Michael Thonet.

Ledermann sgabello counter

Cod.10.0602
Design Tom Kelley
Anno di produzione 2018



Sgabello con struttura in legno a quattro gambe di forma conica, con seduta e schienale rivestiti in cuoio. Sedile con fondo in lamiera rivestita con tessuto tecnico di colore nero. Lo schienale può essere completamente rivestito oppure caratterizzato da una singola fascia nella versione "light".

Materiali di struttura disponibili

FG - Frassino grigio
FS - Frassino sbiancato
FR - Frassino naturale

Materiali di rivestimento disponibili

CPF - Cuoio pieno fiore (30 colori)
CTT - Cuoio contract (15 colori)

Per verificare i colori disponibili consultare la scheda finiture.

Info tecniche

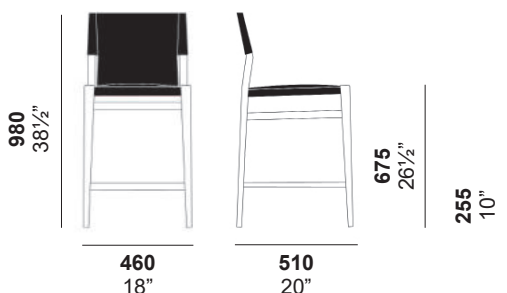

Dimensioni
57 x 60 x 102 cm
22 1/2 x 23 3/4 x 40 inches

Tipo Cartone



Peso Netto 5.5 kg/ 12 lb
Peso Lordo 7.5 kg/ 16.5 lb



Volume 0.348 m³

Le misure riportate sono in
millimetri e inches.

Design

Tom Kelley



Nato nella Germania dell'Est, dopo problemi politici e dopo essere stato rinchiuso in prigione dalla Stasi, studia ad Aquisgrana, Monaco e poi a Long Beach (California). Prima pittore e poi designer, ha portato il suo lavoro e i suoi studi in Italia, dove vive da circa 20 anni a Venezia. Ha lavorato per molte aziende in diversi paesi. Sempre alla ricerca della semplicità, si considera prima di tutto un osservatore e ritiene che dopo un po' tutte le sue osservazioni vogliono uscire fuori in forme, composizioni, colori, progetti, parole. In questi ultimi anni, oltre alla preminente attività di designer, ha restaurato case private tra cui la villa del famoso Michael Thonet.

Ledermann bar stool

Cod.10.0603
Design Tom Kelley
Production year 2018

Ledermann bar stool has a wooden frame with 4 legs, in tubular conical shape. Seat and back are covered with leather. Seat with bottom in sheet metal covered with black technical fabric. Back can be completely covered, joining to the seat or just with a leather strap in "light" version.

Structure materials available

FG - Grey ash
FS - Bleached ash
FR - Natural ash

Covering materials available

CPF - Full grain leather (30 colors)
CTT - Contract leather (15 colors)

To check the available colors, consult the finishing catalogue.



Technical information

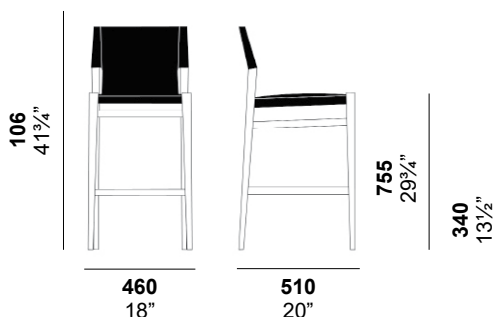

Dimensions
57 x 60 x 110 cm
22 1/2 x 23 3/4 x 43 1/4 inches

Type Carton



Net weight 6 kg/ 13.2 lb
Gross weight 8 kg/ 17 lb



Volume 0.376 m³

All measurements in
millimetres and inches

Design

Tom Kelley



Born in East-Germany, after political problems and Stasi-Prison he studies in Aachen, Munich and then in Long Beach (California). Initially both painter and designer, brought by his work and studies to Italy, where he lives more or less since 20 years in Venice. He worked for many companies in several countries. Looking always for simplicity, he sees himself as primarily an observer, and believes that after a while all its observations become shapes, colors, projects and words. In these last recent years, in addition to the prominent work as designer, he restored private houses, including the famous Villa of Michael Thonet.

Ledermann sgabello bar

Cod.10.0603
Design Tom Kelley
Anno di produzione 2018

Sgabello con struttura in legno a quattro gambe di forma conica, con seduta e schienale rivestiti in cuoio. Sedile con fondo in lamiera rivestita con tessuto tecnico di colore nero. Lo schienale può essere completamente rivestito oppure caratterizzato da una singola fascia nella versione "light".

Materiali di struttura disponibili

FG - Frassino grigio
FS - Frassino sbiancato
FR - Frassino naturale

Materiali di rivestimento disponibili

CPF - Cuoio pieno fiore (30 colori)
CTT - Cuoio contract (15 colori)

Per verificare i colori disponibili consultare la scheda finiture.



Info tecniche

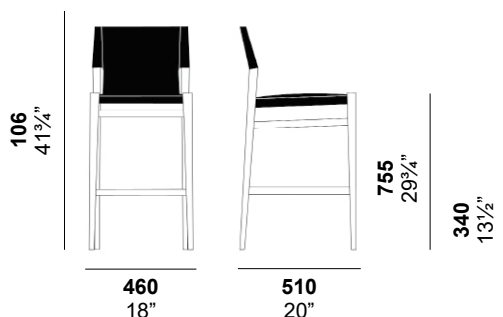

Dimensioni
57 x 60 x 110 cm
22 1/2 x 23 3/4 x 43 1/4 inches

Tipo Cartone



Peso Netto 6 kg/ 13.2 lb
Peso Lordo 8 kg/ 17 lb



Volume 0.376 m³

Le misure riportate sono in
millimetri e inches.

Design

Tom Kelley



Nato nella Germania dell'Est, dopo problemi politici e dopo essere stato rinchiuso in prigione dalla Stasi, studia ad Aquisgrana, Monaco e poi a Long Beach (California). Prima pittore e poi designer, ha portato il suo lavoro e i suoi studi in Italia, dove vive da circa 20 anni a Venezia. Ha lavorato per molte aziende in diversi paesi. Sempre alla ricerca della semplicità, si considera prima di tutto un osservatore e ritiene che dopo un po' tutte le sue osservazioni vogliono uscire fuori in forme, composizioni, colori, progetti, parole. In questi ultimi anni, oltre alla preminente attività di designer, ha restaurato case private tra cui la villa del famoso Michael Thonet.