

Collection **ATLANTE**

Atlante is a system which offers above all the possibility to be used for all kind of projects and to be made in custom size for every kind of available space.

Atlante can be adapted to every environment since it can have many different looks depending from the room where you put it and from its use: the doors can be very simple, with linear and essential design, but changing the finishing, the covering or the model they can be characterized by a stronger aesthetic impact, influencing also the surrounding.

The structure of this wardrobe gives the idea of solidity thanks to the 4 cm thickness of all the sides and its internal fitting offers a wide range of possibilities in order to recreate the best solution according to everyone's needs.

Atlante is available with hinged and sliding doors.

For hinged doors there are six models available:

SEVENTY: characterized by a flush handle which is always in the same finish of the door giving a perfect homogenous surface to the doors

CLIP: characterized by an aluminum handle

SHEER: a unique door with an handle that is not visible from outside since it is created within the thickness of the door, its linearity and plain design allow to use it in every contest

WIND: with burnished profiles and transparent, bronze or smoked glass (upon request it is possible to have also stopsol glass)

CHARME: door characterized by a special handle composed by two parts, one in metal (bronze or graphite) and one that can be in wood, lacquered, hard leather or leather

FLORES : door with an important long metal handle titanium or bronze colour as the profile put along the thickness of the door

Door SEVENTY "Plain" : mat lacquered in our selected colours, mat by sample, veneer wengè, black walnut, smoked oak, grey oak, natural oak, ash stained beige/grey and eucalyptus
SEVENTY "Mirror" : panel in natural mirror – aluminum profile on the doors' thickness
SEVENTY "Glossy Glass" : panel in lacquered glass in our selected colours – aluminium profile on the doors' thickness



design Pietro Arosio

Door CLIP "Plain" : mat lacquered in our selected colours, mat by sample, veneer wengè, black walnut, smoked oak, grey oak, natural oak, ash stained beige/grey and eucalyptus
CLIP "Mirror" : panel in natural mirror – aluminum profile on the doors' thickness
CLIP "Glossy Glass" : panel in lacquered glass in our selected colours – aluminium profile on the doors' thickness
CLIP "Hard leather or regenerated leather" : covered with regenerated hard leather available in 5 colours (white, sand, toupe, dark brown and black) or with regenerated leather available in 5 colours (cream, sand, beige, talpa, brown) – stitching can be in the same colour or in a contrasting one



design Pietro Arosio

- Door SHEER "Plain" : mat lacquered in our selected colours, mat by sample, veneer wengè, black walnut, smoked oak, grey oak, natural oak, ash stained beige/grey and eucalyptus
SHEER "Mirror" : panel in natural mirror - profile mat lacquered in our selected colours or mat by sample
SHEER "Fabric" : panel covered with client's fabric - profile mat lacquered in our selected colours or mat by sample
SHEER "Glossy Glass" : panel in glass, lacquered in our selected colours - profile mat lacquered in our selected colours or mat by sample



design Pietro Arosio

- Door WIND : burnished handle and profiles, transparent, bronze or smoked glass (upon request it is possible to have also stopsol glass)



design Pietro Arosio

- Door CHARME "Plain": mat lacquered in our selected colours, mat by sample, veneer wengè, black walnut, smoked oak, grey oak, natural oak, ash stained beige/grey and eucalyptus
CHARME "Hard leather" or "regenerated leather" : covered with regenerated hard leather available in 5 colours (white, sand, toupe, dark brown and black) or or with regenerated leather available in 5 colours (cream, sand, beige, talpa, brown) – stitching can be in the same colour or in a contrasting one



design: Pierangelo Sciuto

- Door FLORES "Plain": mat lacquered in our selected colours, mat by sample, veneer wengè, black walnut, smoked oak, grey oak, natural oak, ash stained beige/grey, eucalyptus
FLORES "natural mirror" : metal profile along the thickness titanium or bronze colour, mirror panel, internal finish of the doors mat lacquered in our selected colours, veneer wengè, black walnut, smoked oak, grey oak, natural oak, ash stained beige/grey, eucalyptus

FLORES "regenerated leather": covered with regenerated leather available in 5 colours (cream, sand, beige, talpa, brown), metal profile along the thickness titanium or bronze colour, internal finish of the doors mat lacquered in our selected colours, veneer wengè, black walnut, smoked oak, grey oak, natural oak, ash stained beige/grey, eucalyptus
The door Flores when covered with hard leather or regenerated leather is slightly padded, it has a stitching at about half height which enhances the material and the manufacturing



design:Pierangelo Sciuto

For sliding doors, three models are available:

SHEER: a unique door with an handle that is not visible from outside since it is created within the thickness of the door, its linearity and plain design allow to use it in every contest

WIND: with burnished profiles and transparent, bronze or smoked glass (upon request it is possible to have also stopsol glass)

LINE: characterized by doors with vertical profiles which serve as handles

Door **SHEER "Plain"** : mat lacquered in our selected colours, mat by sample, veneer wengè, black walnut, smoked oak, grey oak, natural oak, ash stained beige/grey and eucalyptus

SHEER "Mirror" : panel in natural mirror - profile mat lacquered in our selected colours or mat by sample

SHEER "Fabric" : panel covered with client's fabric - profile mat lacquered in our selected colours or mat by sample

SHEER "Glossy Glass" : panel in glass, lacquered in our selected colours - profile mat lacquered in our selected colours or mat by sample



D

design:Pietro Arosio

Door **WIND** : burnished handle and profiles, transparent, bronze or smoked glass (upon request it is possible to have also stopsol glass)



design Pietro Arosio

Door LINE "Plain": mat lacquered in our selected colours, mat by sample, veneer wengè, black walnut, smoked oak, grey oak, natural oak, ash stained beige/grey and eucalyptus; the handle will be lacquered if the door is lacquered while it will be in wood if the door is in wood
 LINE "Mirror": panel in natural mirror; the handle will be mat lacquered in our selected colours
 LINE "Glossy Glass": panel in glass, lacquered in our selected colours; the handle will be mat lacquered in the same colour of the panel



design: CRS EmmeBi

External sides: mat lacquered in our selected colours, mat by sample, veneer wengè, black walnut, smoked oak, grey oak, natural oak, ash stained beige/grey and eucalyptus

Internal finish: mat lacquered in our selected colours, mat by sample, veneer wengè, black walnut, dark walnut, smoked oak, grey oak, natural oak, ash stained beige/grey and eucalyptus

It is possible to cover the sides, the backpanels and the internal fitting with hard leather, regenerated leather or nabuk

Dimensions:

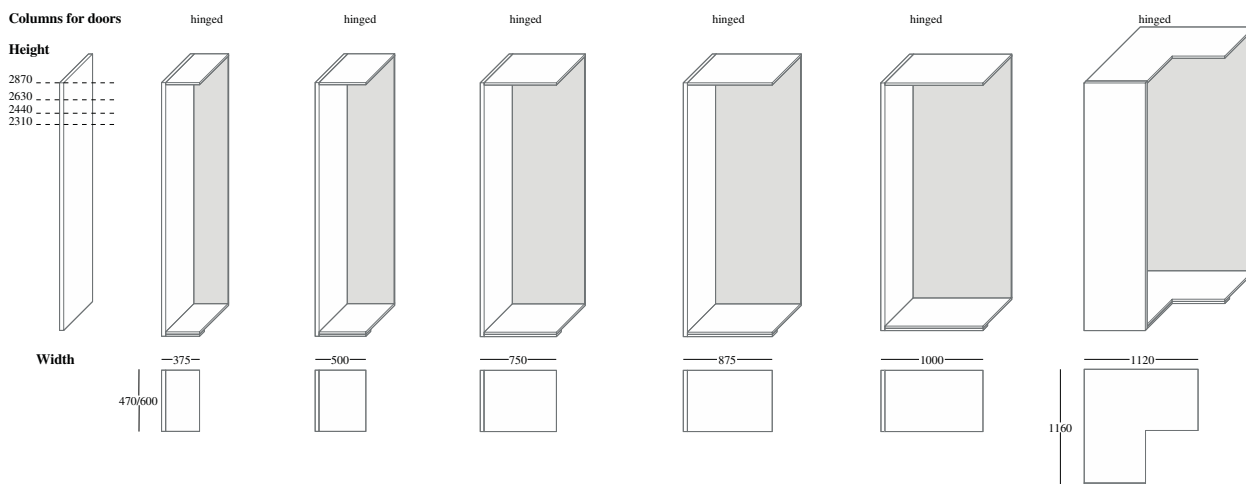

Chamfered columns

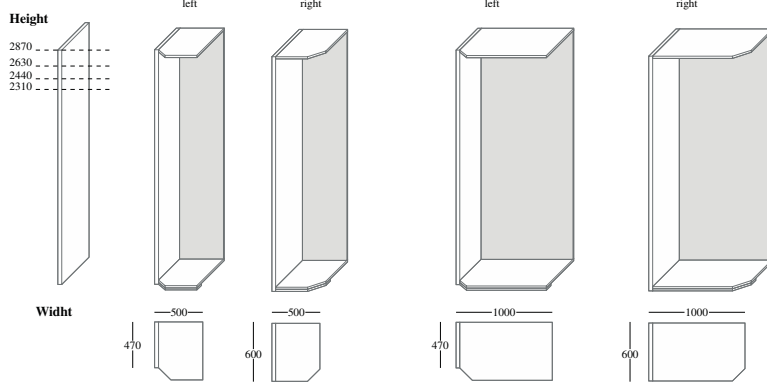

Chamfered en element

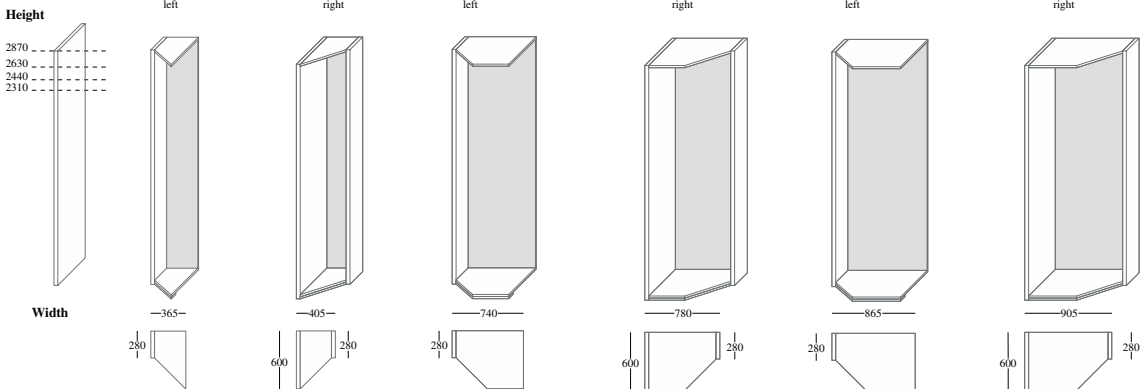

Columns for sliding doors

