

# Stabligh - 3 colors

Arik Levy

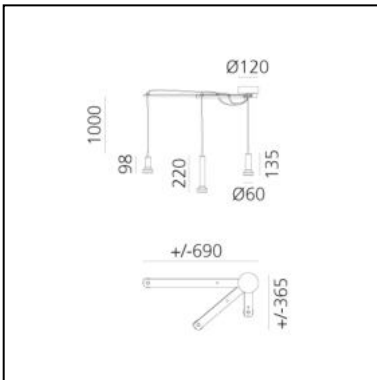

IP20  



## LUMINAIRE

- Watt: **16,5W**
- Delivered lumens output: **1019lm**
- Efficiency: **97%**
- Efficacy: **63.66lm/W**
- CRI: **90**

## DESCRIPTION

The Stab light are produced with very traditional bohemian handblowing technology. Its handblowing to wooden moulds. The moulds are produced by hand as well, from hard and wet wood. The glass masters are using glass blowing pipe as basic instrument, gathering several layers of glass in various colors and by mouth blowing and shaping with hand tools prepares shape which is very close to the moulds shape. In final stage the glass masters puts the pre-shaped hot glass into the mould and finish the piece to the final shape, which is given by exact form of the mould. After the "hotshop" production phase the vases are finished on cutting shop, where additional parts are cutted out and surface is polished to high gloss. This production process stays on extraordinary skills of glass masters, who are passing their experience from generation to generation.

**PRODUCT CODE: DAL0027L90**

## FEATURES

- Article Code: **DAL0027L90**
- Colour: **Brown, green amber, aquamarine**
- Installation: **Suspension**
- Material: **blown glass, metal**
- Series: **Design Collection**
- Environment: **Indoor**
- design by: **Arik Levy**

## DIMENSIONS

- Base Diameter: **cm 12**
- Max Extension Length: **cm 73**

## SOURCES NOT INCLUDED

- Category: **LED RETROFIT**
- Number: **3**
- Socket: **GU10**

# Stabligh - Aquamarine

Arik Levy



IP20  

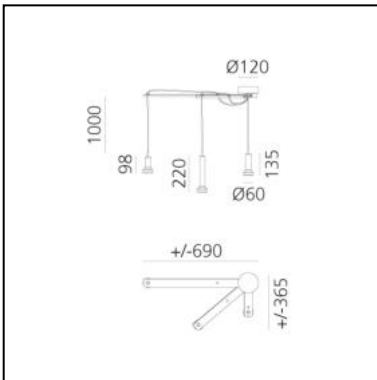

## LUMINAIRE

- Watt: **16,5W**
- Delivered lumens output: **1019lm**
- Efficiency: **97%**
- Efficacy: **63.66lm/W**
- CRI: **90**

## DESCRIPTION

The Stab light are produced with very traditional bohemian handblowing technology. Its handblowing to wooden moulds. The moulds are produced by hand as well, from hard and wet wood. The glass masters are using glass blowing pipe as basic instrument, gathering several layers of glass in various colors and by mouth blowing and shaping with hand tools prepares shape which is very close to the moulds shape. In final stage the glass masters puts the pre-shaped hot glass into the mould and finish the piece to the final shape, which is given by exact form of the mould. After the "hotshop" production phase the vases are finished on cutting shop, where additional parts are cut out and surface is polished to high gloss. This production process stays on extraordinary skills of glass masters, who are passing their experience from generation to generation.

**PRODUCT CODE: DAL0027L14**

## FEATURES

- Article Code: **DAL0027L14**
- Colour: **Aquamarine**
- Installation: **Suspension**
- Material: **blown glass, metal**
- Series: **Design Collection**
- Environment: **Indoor**
- design by: **Arik Levy**

## DIMENSIONS

- Base Diameter: **cm 12**
- Max Extension Length: **cm 73**

## SOURCES NOT INCLUDED

- Category: **LED RETROFIT**
- Number: **3**
- Socket: **GU10**

# Stablight "C" - Brown

Arik Levy



IP20  

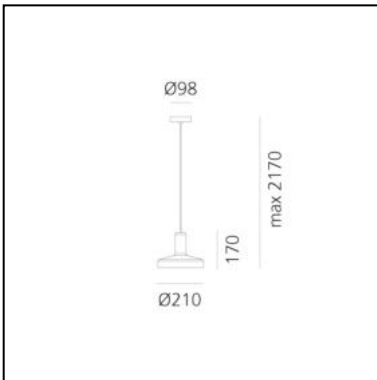

## LUMINAIRE

- Watt: **5,5W**
- Delivered lumens output: **340lm**
- Efficiency: **97%**
- Efficacy: **67.90lm/W**
- CRI: **90**

## DESCRIPTION

The Stab light are produced with very traditional bohemian handblowing technology. Its handblowing to wooden moulds. The moulds are produced by hand as well, from hard and wet wood. The glass masters are using glass blowing pipe as basic instrument, gathering several layers of glass in various colors and by mouth blowing and shaping with hand tools prepares shape which is very close to the moulds shape. In final stage the glass masters puts the pre-shaped hot glass into the mould and finish the piece to the final shape, which is given by exact form of the mould. After the "hotshop" production phase the vases are finished on cutting shop, where additional parts are cutted out and surface is polished to high gloss. This production process stays on extraordinary skills of glass masters, who are passing their experience from generation to generation.

**PRODUCT CODE: DAL0027080**

## FEATURES

- Article Code: **DAL0027080**
- Colour: **Brown**
- Installation: **Suspension**
- Material: **blown glass, metal**
- Series: **Design Collection**
- Environment: **Indoor**
- design by: **Arik Levy**

## DIMENSIONS

- Height: **cm 17**
- Diameter: **cm 21**
- Base Diameter: **cm 9.8**
- Max Extension Height: **cm 200**

## SOURCES NOT INCLUDED

- Category: **LED RETROFIT**
- Number: **1**
- Socket: **GU10**

# Stabligh "B" - Green amber

Arik Levy



IP20  

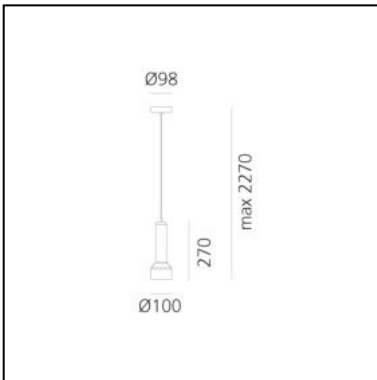

## LUMINAIRE

- Watt: **5,5W**
- Delivered lumens output: **340lm**
- Efficiency: **97%**
- Efficacy: **67.90lm/W**
- CRI: **90**

## DESCRIPTION

The Stab light are produced with very traditional bohemian handblowing technology. Its handblowing to wooden moulds. The moulds are produced by hand as well, from hard and wet wood. The glass masters are using glass blowing pipe as basic instrument, gathering several layers of glass in various colors and by mouth blowing and shaping with hand tools prepares shape which is very close to the moulds shape. In final stage the glass masters puts the pre-shaped hot glass into the mould and finish the piece to the final shape, which is given by exact form of the mould. After the "hotshop" production phase the vases are finished on cutting shop, where additional parts are cutted out and surface is polished to high gloss. This production process stays on extraordinary skills of glass masters, who are passing their experience from generation to generation.

**PRODUCT CODE: DAL0027N12**

## FEATURES

- Article Code: **DAL0027N12**
- Colour: **Green amber**
- Installation: **Suspension**
- Material: **blown glass, metal**
- Series: **Design Collection**
- Environment: **Indoor**
- design by: **Arik Levy**

## DIMENSIONS

- Height: **cm 27**
- Diameter: **cm 10**
- Base Diameter: **cm 9.8**
- Max Extension Height: **cm 200**

## SOURCES NOT INCLUDED

- Category: **LED RETROFIT**
- Number: **1**
- Socket: **GU10**

# Stabligh "A" - Aquamarine

Arik Levy



IP20  

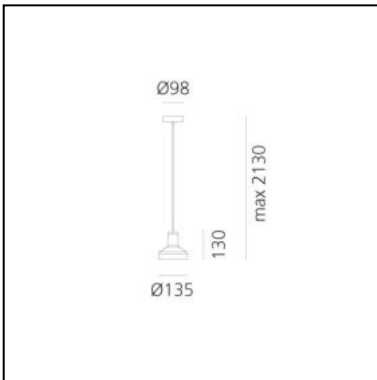

## LUMINAIRE

- Watt: **5,5W**
- Delivered lumens output: **340lm**
- Efficiency: **97%**
- Efficacy: **67.90lm/W**
- CRI: **90**

## DESCRIPTION

The Stab light are produced with very traditional bohemian handblowing technology. Its handblowing to wooden moulds. The moulds are produced by hand as well, from hard and wet wood. The glass masters are using glass blowing pipe as basic instrument, gathering several layers of glass in various colors and by mouth blowing and shaping with hand tools prepares shape which is very close to the moulds shape. In final stage the glass masters puts the pre-shaped hot glass into the mould and finish the piece to the final shape, which is given by exact form of the mould. After the "hotshop" production phase the vases are finished on cutting shop, where additional parts are cutted out and surface is polished to high gloss. This production process stays on extraordinary skills of glass masters, who are passing their experience from generation to generation.

**PRODUCT CODE: DAL0027M14**

## FEATURES

- Article Code: **DAL0027M14**
- Colour: **Aquamarine**
- Installation: **Suspension**
- Material: **blown glass, metal**
- Series: **Design Collection**
- Environment: **Indoor**
- design by: **Arik Levy**

## DIMENSIONS

- Height: **cm 13**
- Diameter: **cm 9.8**
- Base Diameter: **cm 10**
- Max Extension Height: **cm 200**

## SOURCES NOT INCLUDED

- Category: **LED RETROFIT**
- Number: **1**
- Socket: **GU10**