

FNS 7140 E

Built-in freezer

with Frost free and four freezer drawers for maximum convenience.



- No icing up of food and no need to defrost thanks to NoFrost
- Food is frozen quickly and gently – SuperFreeze
- Flexible increase in freezer volume – VarioRoom



EAN: 4002516379416 / Material number: 11643190 / Old Material Number: 37714000EU1

<b>Appliance category</b>	
Freezer	•
<b>Construction type</b>	
Built-in appliance	•
Integrated appliance	•
Door hinge	right
Convertible door hinging	•
Side-by-side enabled	•
<b>User convenience</b>	
Networking with Miele@home	•
NoFrost	•
VarioRoom	•
SoftClose, can be retrofitted	•
<b>Controls</b>	
Operating concept	SensorTouch
Independent temperature regulation of fridge and freezer zones	No
SuperFreeze	•
No. of temperature zones	1
Sabbath mode	•
Party mode	•
<b>Freezer/Freezer section</b>	
Number of freezer drawers	4
<b>Efficiency and sustainability</b>	
Energy efficiency class (A–G)	E
Annual energy consumption in kWh	191.42
Energy consumption in 24 h in kWh	0.52
<b>Safety</b>	
Lock function	•
Acoustic door alarm	•
Acoustic temperature alarm	•
Optical door alarm	•
Optical temperature alarm	•
Power cut indication for freezer section	•
<b>Technical data</b>	
Niche width in mm min.	560
Niche width in mm max.	570
Niche height in mm min.	874
Niche height in mm max.	890
Niche depth in mm	550
Appliance width in mm	559
Appliance height in mm	872
Appliance depth in mm	544
Weight in kg	38.0
Door hinge technology	Fixed door
Max. door front weight – refrigerator, in kg	16
Max. door front weight – freezer, in kg	16
Climate class	SN-T
4* freezer compartment in l	87
Storage time in case of fault in h	10

FNS 7140 E

Built-in freezer

with Frost free and four freezer drawers for maximum convenience.



EAN: 4002516379416 / Material number: 11643190 / Old Material Number: 37714000EU1

Freezer capacity in kg/24 h	10.00
Noise class (A-D)	B
Sound power in dB(A) re 1 pW	35
Current consumption (mA)	1300
Voltage in V	220-240
Fuse rating in A	10
Number of phases	1
Frequency in Hz	50-60
Length of supply lead in m	2.2
Replacing lamps	Customer Service
<b>Accessories supplied</b>	
Ice cube tray	•

FNS 7140 E  
 Built-in freezer  
 with Frost free and four freezer drawers for maximum convenience.

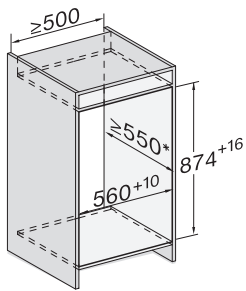

FNS7140E, built-in (\*footnote) (installation drawings)

\*The declared energy consumption was calculated in a 560 mm deep niche. The appliance is fully functional in a 550 mm niche but the energy consumption will be slightly higher.

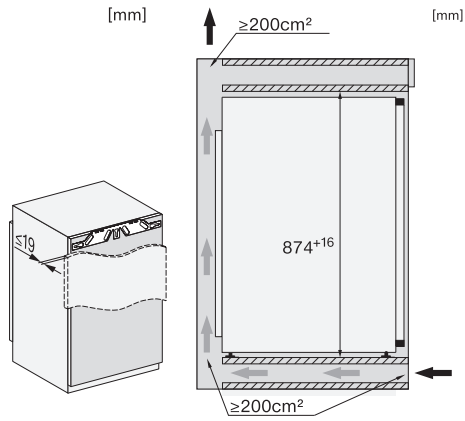

FNS7140E, side view (installation drawings) (US)

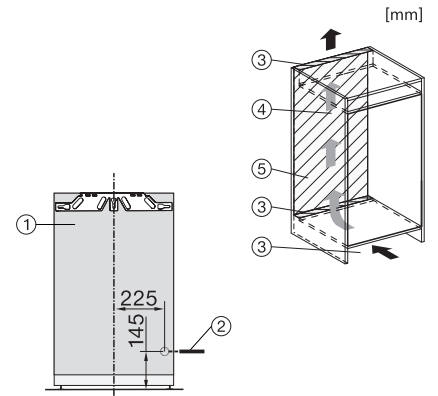

FNS7140E, installation (\*footnote) (installation drawings) (US)

\*1. View from the front, 2. Mains connection cable, L = 2200 mm, 3. Ventilation cut-out min. 200 cm<sup>2</sup>, 4. Ventilation, 5. No connections permitted in this area