

SERIP

Diamond Tiara

REFERENCE AP1424/6



DESCRIPTION

Inspired by handcrafted jewellery. The Diamond Collection highlights a sense of luxury through the brightness of its imperial display. Opulent and extravagant, the collection reminisces on the hypnotizing glow of Sapphires, Emeralds, Ambar and Rubies. The rings of metal branches were carefully designed to incorporate nearly hundreds of gleaming stones, all for a final result of incredible shine and class, increasing to the measure of its length. Ideal for classic interiors, framing perfectly in bedrooms, dining and living rooms.

Finish shown here Metal FP | Glass 10+12+14

Designed and produced by hand in Portugal.

Serip reserves the right to make changes or improvements at any time it deems useful to guarantee the highest quality standards for its products.

Hand-finished, some variations may occur.

All the glass models are designed by Serip and exclusively handmade produced, establishing a unique and prestigious feature of the glass handwork art. For this reason, there is the possibility of variation in measures, weight, colour and shape represented.

TECHNICAL DRAWING

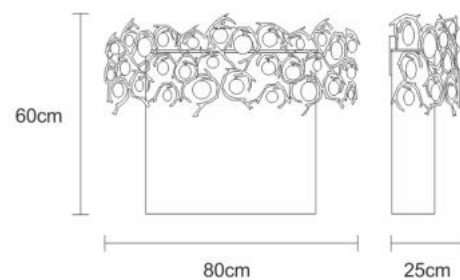

SERIP

TECHNICAL SPECIFICATIONS

MEASUREMENTS

FIXTURE SIZE & WEIGHT

Width 80cm / 31in

Height 60cm / 24in

Depth 25cm / 10in

Weight 6kg / 13lb

PACKAGE SIZE & WEIGHT

(m)Package 1/2 0.95cm x 0.50cm x 0.95cm
=0.45CBM

(in)Package 1/2 0.37in x 0.20in x 0.37in
=15.93US GAL

ELECTRIC FEATURE

Installation Wall
IP degree IP 20

220-240V 50Hz-60Hz
Max Power Consumption 240W
Light Sources
6 x G9 Max 40W

Included Sources

Light Sources
6 x G9 LED 2W
Lumens 1380lm
Kelvin 3000
CRI 80

Optional Sources

Light Sources
6 x G9 LED 3W
Lumens 1800lm
Kelvin 3000
CRI 80

110-120V 50Hz-60Hz
Max Power Consumption 240W
Light Sources
6 x G9 Max 40W

ENERGY RATING

This luminaire allows lights sources with energy efficiency class

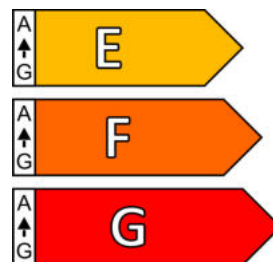

CERTIFICATIONS



CARE INSTRUCTIONS

Due to the nature of our exquisite hand applied finishes, wipe clean with a soft, dry cloth or static duster must be used to clean the fixture.

Always avoid the use of harsh chemicals or abrasive cleaners as they may cause damage to the fixture's finish.

Cleaning is limited to the outer surfaces, shades or glass. It is important to ensure that no moisture enters the terminal compartment or reaches any live parts.

As our products are subject to technical modifications, we cannot guarantee, that all information is always up to date. Please contact our [technical department](#) with any queries.

SERIP

OPTIONAL FINISHES

GLASS FINISHES



Emerald (40)



Smoked (34)



Black (14)



Amber (11)



Clear (10)



Blue (09)

METAL FINISHES



Copper
(CO)



Silver (FP)



Silver/White
Patina
(FP/PB)



Lead (CH)



Palladium
(PL)



Black (PR)



Gold/White
Patina
(FO/PB)



Gold (FO)



Talha (TA)

SERIP

SERIP

Diamond Persa Square

REFERENCE CT3295/5

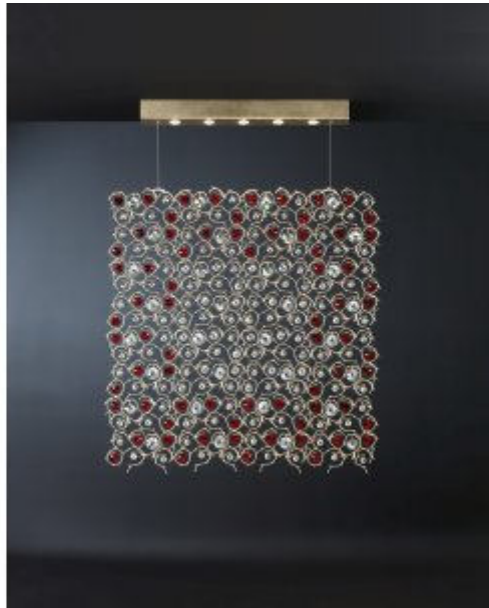

DESCRIPTION

Inspired by handcrafted jewellery. The Diamond Collection highlights a sense of luxury through the brightness of its imperial display. Opulent and extravagant, the collection reminisces on the hypnotizing glow of Sapphires, Emeralds, Ambar and Rubies. The rings of metal branches were carefully designed to incorporate nearly hundreds of gleaming stones, all for a final result of incredible shine and class, increasing to the measure of its length. Ideal for classic interiors, framing perfectly in bedrooms, dining and living rooms.

Finish shown here Metal FP | Glass 08+10

Designed and produced by hand in Portugal.

Serip reserves the right to make changes or improvements at any time it deems useful to guarantee the highest quality standards for its products.

Hand-finished, some variations may occur.

All the glass models are designed by Serip and exclusively handmade produced, establishing a unique and prestigious feature of the glass handwork art. For this reason, there is the possibility of variation in measures, weight, colour and shape represented.

TECHNICAL DRAWING

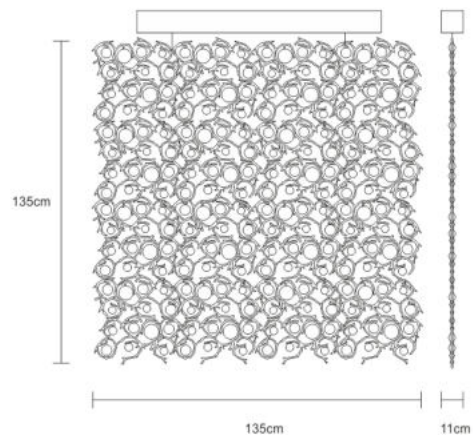

SERIP

TECHNICAL SPECIFICATIONS

MEASUREMENTS

FIXTURE SIZE & WEIGHT

Width 9cm / 4in

Height 135cm / 53in

Lenght 135cm / 53in

OAH Overall Heigth Min 150cm / 59in

OAH Overall Heigth Max 430cm / 169in

Weight 28kg / 62lb

PACKAGE SIZE & WEIGHT

(m)Package 1/2 1.50cm x 0.60cm x 1.70cm

=1.53CBM

(in)Package 1/2 0.59in x 0.24in x 0.67in

=54.02US GAL

ELECTRIC FEATURE

Installation Ceiling

IP degree IP 20

220-240V 50Hz-60Hz

Max Power Consumption 250W

Light Sources

5 x GU10 Max 50W

Included Sources

Light Sources

5 x GU10 LED 6W

Lumens 1150lm

Kelvin 3000

CRI 90

110-120V 50Hz-60hZ

Max Power Consumption 250W

Light Sources

5 x GU10 Max 50W

ENERGY RATING

This luminaire allows lights sources with energy efficiency class



CERTIFICATIONS



CARE INSTRUCTIONS

Due to the nature of our exquisite hand applied finishes, wipe clean with a soft, dry cloth or static duster must be used to clean the fixture.

Always avoid the use of harsh chemicals or abrasive cleaners as they may cause damage to the fixture's finish.

Cleaning is limited to the outer surfaces, shades or glass. It is important to ensure that no moisture enters the terminal compartment or reaches any live parts.

As our products are subject to technical modifications, we cannot guarantee, that all information is always up to date. Please contact our [technical department](#) with any queries.

SERIP

OPTIONAL FINISHES

GLASS FINISHES



Emerald (40)



Smoked (34)



Black (14)



Amber (11)



Clear (10)



Blue (09)

METAL FINISHES



Copper
(CO)



Silver (FP)



Silver/White
Patina
(FP/PB)



Lead (CH)



Palladium
(PL)



Black (PR)



Gold/White
Patina
(FO/PB)



Gold (FO)



Talha (TA)

Note The canopy has only the base finish colour. The metal finish is without patina or texture of another tone. Except for Talha and Black finishes.

SERIP

Diamond Persa Rectangle

REFERENCE CT3318/4



DESCRIPTION

Inspired by handcrafted jewellery. The Diamond Collection highlights a sense of luxury through the brightness of its imperial display. Opulent and extravagant, the collection reminisces on the hypnotizing glow of Sapphires, Emeralds, Ambar and Rubies. The rings of metal branches were carefully designed to incorporate nearly hundreds of gleaming stones, all for a final result of incredible shine and class, increasing to the measure of its length. Ideal for classic interiors, framing perfectly in bedrooms, dining and living rooms.

Finish shown here Metal FO | Glass 10

Designed and produced by hand in Portugal.

Serip reserves the right to make changes or improvements at any time it deems useful to guarantee the highest quality standards for its products.

Hand-finished, some variations may occur.

All the glass models are designed by Serip and exclusively handmade produced, establishing a unique and prestigious feature of the glass handwork art. For this reason, there is the possibility of variation in measures, weight, colour and shape represented.

TECHNICAL DRAWING

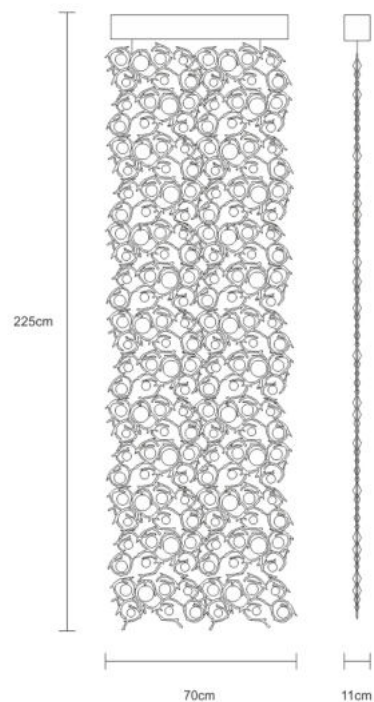

TECHNICAL SPECIFICATIONS

MEASUREMENTS

FIXTURE SIZE & WEIGHT

Width 9cm / 4in

Height 215cm / 85in

Length 70cm / 28in

OAH Overall Height Min 230cm / 91in

OAH Overall Height Max 0cm / 500in

Weight 23kg / 51lb

PACKAGE SIZE & WEIGHT

(m)Package 1/2 0.90cm x 0.60cm x 2.40cm

=1.30CBM

(in)Package 1/2 0.35in x 0.24in x 0.94in

=45.76US GAL

ELECTRIC FEATURE

Installation Ceiling

IP degree IP 20

220-240V 50Hz-60Hz

Max Power Consumption 200W

Light Sources

4 x GU10 Max 50W

Included Sources

Light Sources

4 x GU10 LED 6W

Lumens 920lm

Kelvin 3000

CRI 90

110-120V 50Hz-60Hz

Max Power Consumption 200W

Light Sources

4 x GU10 Max 50W

ENERGY RATING

This luminaire allows lights sources with energy efficiency class



CERTIFICATIONS



CARE INSTRUCTIONS

Due to the nature of our exquisite hand applied finishes, wipe clean with a soft, dry cloth or static duster must be used to clean the fixture.

Always avoid the use of harsh chemicals or abrasive cleaners as they may cause damage to the fixture's finish.

Cleaning is limited to the outer surfaces, shades or glass. It is important to ensure that no moisture enters the terminal compartment or reaches any live parts.

As our products are subject to technical modifications, we cannot guarantee, that all information is always up to date. Please contact our [technical department](#) with any queries.

SERIP

OPTIONAL FINISHES

GLASS FINISHES



Emerald (40)



Smoked (34)



Black (14)



Amber (11)



Clear (10)



Blue (09)

METAL FINISHES



Copper
(CO)



Silver (FP)



Silver/White
Patina
(FP/PB)



Lead (CH)



Palladium
(PL)



Black (PR)



Gold/White
Patina
(FO/PB)



Gold (FO)



Talha (TA)

Note The canopy has only the base finish colour. The metal finish is without patina or texture of another tone. Except for Talha and Black finishes.

SERIP

SERIP

Diamond Luxor

REFERENCE PA626/8



DESCRIPTION

Inspired by handcrafted jewellery. The Diamond Collection highlights a sense of luxury through the brightness of its imperial display. Opulent and extravagant, the collection reminisces on the hypnotizing glow of Sapphires, Emeralds, Ambar and Rubies. The rings of metal branches were carefully designed to incorporate nearly hundreds of gleaming stones, all for a final result of incredible shine and class, increasing to the measure of its length. Ideal for classic interiors, framing perfectly in bedrooms, dining and living rooms.

Finish shown here Metal FO | Glass 10

Designed and produced by hand in Portugal.

Serip reserves the right to make changes or improvements at any time it deems useful to guarantee the highest quality standards for its products.

Hand-finished, some variations may occur.

All the glass models are designed by Serip and exclusively handmade produced, establishing a unique and prestigious feature of the glass handwork art. For this reason, there is the possibility of variation in measures, weight, colour and shape represented.

TECHNICAL DRAWING

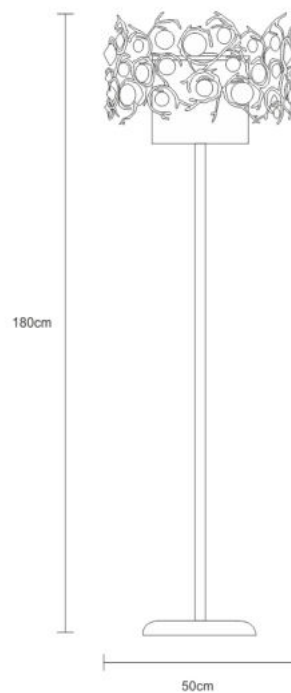

SERIP

TECHNICAL SPECIFICATIONS

MEASUREMENTS

Height 180cm / 71in

Weight 22kg / 49lb

PACKAGE SIZE & WEIGHT

(m)Package 1/2 0.85cm x 1.00cm x 2.03cm
=1.73CBM

(in)Package 1/2 0.33in x 0.39in x 0.80in
=60.93US GAL

ELECTRIC FEATURE

Installation Floor lamp
IP degree IP 20

220-240V 50Hz-60Hz
Max Power Consumption 200W
Light Sources
8 x G9 Max 25W

Included Sources

Light Sources
8 x G9 LED 3,5W
Lumens 2800lm
Kelvin 2700
CRI 80

110-120V 50Hz-60Hz
Max Power Consumption 200W
Light Sources
8 x G9 Max 25W

ENERGY RATING

This luminaire allows lights sources with energy efficiency class

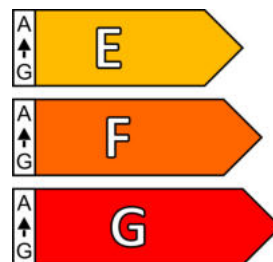

CERTIFICATIONS



CARE INSTRUCTIONS

Due to the nature of our exquisite hand applied finishes, wipe clean with a soft, dry cloth or static duster must be used to clean the fixture.

Always avoid the use of harsh chemicals or abrasive cleaners as they may cause damage to the fixture's finish.

Cleaning is limited to the outer surfaces, shades or glass. It is important to ensure that no moisture enters the terminal compartment or reaches any live parts.

As our products are subject to technical modifications, we cannot guarantee, that all information is always up to date. Please contact our [technical department](#) with any queries.

SERIP

OPTIONAL FINISHES

GLASS FINISHES



Emerald (40)



Smoked (34)



Black (14)



Amber (11)



Clear (10)



Blue (09)

METAL FINISHES



Copper
(CO)



Silver (FP)



Silver/White
Patina
(FP/PB)



Lead (CH)



Palladium
(PL)



Black (PR)



Gold/White
Patina
(FO/PB)



Gold (FO)



Talha (TA)

SERIP

SERIP

Diamond Cleopatra Small

REFERENCE CT3249/4



DESCRIPTION

Inspired by handcrafted jewellery. The Diamond Collection highlights a sense of luxury through the brightness of its imperial display. Opulent and extravagant, the collection reminisces on the hypnotizing glow of Sapphires, Emeralds, Ambar and Rubies. The rings of metal branches were carefully designed to incorporate nearly hundreds of gleaming stones, all for a final result of incredible shine and class, increasing to the measure of its length. Ideal for classic interiors, framing perfectly in bedrooms, dining and living rooms.

Finish shown here Metal FO | Glass 11+12+34+40

Designed and produced by hand in Portugal.

Serip reserves the right to make changes or improvements at any time it deems useful to guarantee the highest quality standards for its products.

Hand-finished, some variations may occur.

All the glass models are designed by Serip and exclusively handmade produced, establishing a unique and prestigious feature of the glass handwork art. For this reason, there is the possibility of variation in measures, weight, colour and shape represented.

TECHNICAL DRAWING

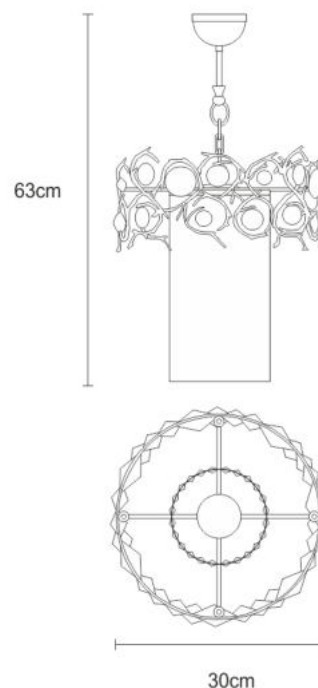

SERIP

TECHNICAL SPECIFICATIONS

MEASUREMENTS

Height 43cm / 17in

OAH Overall Height Min 63cm / 25in

OAH Overall Height Max 90cm / 35in

Weight 5kg / 11lb

PACKAGE SIZE & WEIGHT

(m)Package 1/2 0.64cm x 0.46cm x 0.64cm
=0.19CBM

(in)Package 1/2 0.25in x 0.18in x 0.25in
=6.65US GAL

ELECTRIC FEATURE

Installation Ceiling

IP degree IP 20

220-240V 50Hz-60Hz

Max Power Consumption 160W

Light Sources

4 x G9 Max 40W

Included Sources

Light Sources

4 x G9 LED 2W

Lumens 920lm

Kelvin 3000

CRI 80

Optional Sources

Light Sources

4 x G9 LED 3W

Lumens 1200lm

Kelvin 3000

CRI 80

110-120V 50Hz-60Hz

Max Power Consumption 160W

Light Sources

4 x G9 Max 40W

ENERGY RATING

This luminaire allows lights sources with energy efficiency class



CERTIFICATIONS



CARE INSTRUCTIONS

Due to the nature of our exquisite hand applied finishes, wipe clean with a soft, dry cloth or static duster must be used to clean the fixture.

Always avoid the use of harsh chemicals or abrasive cleaners as they may cause damage to the fixture's finish.

Cleaning is limited to the outer surfaces, shades or glass. It is important to ensure that no moisture enters the terminal compartment or reaches any live parts.

As our products are subject to technical modifications, we cannot guarantee, that all information is always up to date. Please contact our [technical department](#) with any queries.

SERIP

OPTIONAL FINISHES

GLASS FINISHES



Emerald (40)



Smoked (34)



Black (14)



Amber (11)



Clear (10)



Blue (09)

METAL FINISHES



Copper
(CO)



Silver (FP)



Silver/White
Patina
(FP/PB)



Lead (CH)



Palladium
(PL)



Black (PR)



Gold/White
Patina
(FO/PB)



Gold (FO)



Talha (TA)

SERIP

SERIP

Diamond Cleopatra Large

REFERENCE CT3245/8



DESCRIPTION

Inspired by handcrafted jewellery. The Diamond Collection highlights a sense of luxury through the brightness of its imperial display. Opulent and extravagant, the collection reminisces on the hypnotizing glow of Sapphires, Emeralds, Ambar and Rubies. The rings of metal branches were carefully designed to incorporate nearly hundreds of gleaming stones, all for a final result of incredible shine and class, increasing to the measure of its length. Ideal for classic interiors, framing perfectly in bedrooms, dining and living rooms.

Finish shown here Metal FO | Glass 10+11+14

Designed and produced by hand in Portugal.

Serip reserves the right to make changes or improvements at any time it deems useful to guarantee the highest quality standards for its products.

Hand-finished, some variations may occur.

All the glass models are designed by Serip and exclusively handmade produced, establishing a unique and prestigious feature of the glass handwork art. For this reason, there is the possibility of variation in measures, weight, colour and shape represented.

TECHNICAL DRAWING

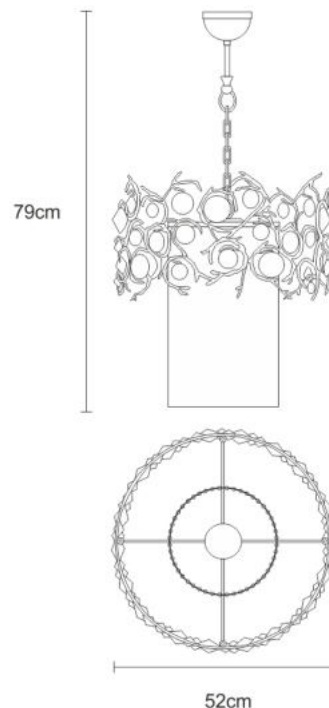

SERIP

TECHNICAL SPECIFICATIONS

MEASUREMENTS

Height 57cm / 22in

OAH Overall Height Min 70cm / 28in

OAH Overall Height Max 90cm / 35in

Weight 9kg / 20lb

PACKAGE SIZE & WEIGHT

(m)Package 1/2 0.94cm x 0.90cm x 0.93cm
=0.79CBM

(in)Package 1/2 0.37in x 0.35in x 0.37in
=27.78US GAL

ELECTRIC FEATURE

Installation Ceiling

IP degree IP 20

220-240V 50Hz-60Hz

Max Power Consumption 320W

Light Sources

8 x G9 Max 40W

Included Sources

Light Sources

8 x G9 LED 2W

Lumens 1840lm

Kelvin 3000

CRI 80

Optional Sources

Light Sources

8 x G9 LED 3W

Lumens 2400lm

Kelvin 3000

CRI 80

110-120V 50Hz-60Hz

Max Power Consumption 320W

Light Sources

8 x G9 Max 40W

ENERGY RATING

This luminaire allows lights sources with energy efficiency class



CERTIFICATIONS



CARE INSTRUCTIONS

Due to the nature of our exquisite hand applied finishes, wipe clean with a soft, dry cloth or static duster must be used to clean the fixture.

Always avoid the use of harsh chemicals or abrasive cleaners as they may cause damage to the fixture's finish.

Cleaning is limited to the outer surfaces, shades or glass. It is important to ensure that no moisture enters the terminal compartment or reaches any live parts.

As our products are subject to technical modifications, we cannot guarantee, that all information is always up to date. Please contact our [technical department](#) with any queries.

SERIP

OPTIONAL FINISHES

GLASS FINISHES



Emerald (40)



Smoked (34)



Black (14)



Amber (11)



Clear (10)



Blue (09)

METAL FINISHES



Copper
(CO)



Silver (FP)



Silver/White
Patina
(FP/PB)



Lead (CH)



Palladium
(PL)



Black (PR)



Gold/White
Patina
(FO/PB)



Gold (FO)



Talha (TA)

SERIP

SERIP

Diamond Cleopatra Extra Large

REFERENCE CT3244/15



DESCRIPTION

Inspired by handcrafted jewellery. The Diamond Collection highlights a sense of luxury through the brightness of its imperial display. Opulent and extravagant, the collection reminisces on the hypnotizing glow of Sapphires, Emeralds, Ambar and Rubies. The rings of metal branches were carefully designed to incorporate nearly hundreds of gleaming stones, all for a final result of incredible shine and class, increasing to the measure of its length. Ideal for classic interiors, framing perfectly in bedrooms, dining and living rooms.

Finish shown here Metal FP | Glass 10

Designed and produced by hand in Portugal.

Serip reserves the right to make changes or improvements at any time it deems useful to guarantee the highest quality standards for its products.

Hand-finished, some variations may occur.

All the glass models are designed by Serip and exclusively handmade produced, establishing a unique and prestigious feature of the glass handwork art. For this reason, there is the possibility of variation in measures, weight, colour and shape represented.

TECHNICAL DRAWING

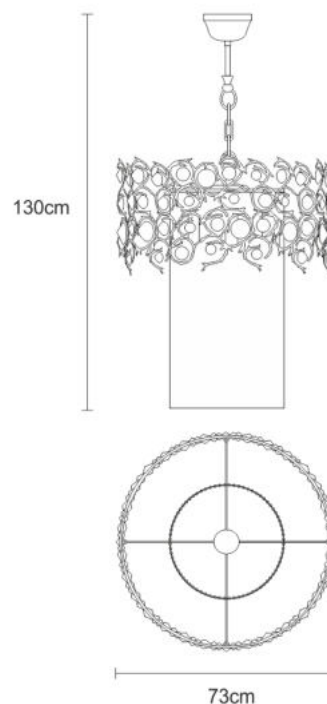

SERIP

TECHNICAL SPECIFICATIONS

MEASUREMENTS

Height 90cm / 35in

OAH Overall Height Min 130cm / 51in

OAH Overall Height Max 160cm / 63in

Weight 18kg / 40lb

PACKAGE SIZE & WEIGHT

(m)Package 1/2 0.95cm x 0.50cm x 0.95cm
=0.45CBM

(in)Package 1/2 0.37in x 0.20in x 0.37in
=15.93US GAL

ELECTRIC FEATURE

Installation Ceiling

IP degree IP 20

220-240V 50Hz-60Hz

Max Power Consumption 600W

Light Sources

15 x G9 Max 40W

Included Sources

Light Sources

15 x G9 LED 2W

Lumens 3450lm

Kelvin 3000

CRI 80

Optional Sources

Light Sources

15 x G9 LED 3W

Lumens 4500lm

Kelvin 3000

CRI 80

110-120V 50Hz-60Hz

Max Power Consumption 600W

Light Sources

15 x G9 Max 40W

ENERGY RATING

This luminaire allows lights sources with energy efficiency class



CERTIFICATIONS



CARE INSTRUCTIONS

Due to the nature of our exquisite hand applied finishes, wipe clean with a soft, dry cloth or static duster must be used to clean the fixture.

Always avoid the use of harsh chemicals or abrasive cleaners as they may cause damage to the fixture's finish.

Cleaning is limited to the outer surfaces, shades or glass. It is important to ensure that no moisture enters the terminal compartment or reaches any live parts.

As our products are subject to technical modifications, we cannot guarantee, that all information is always up to date. Please contact our [technical department](#) with any queries.

SERIP

OPTIONAL FINISHES

GLASS FINISHES



Emerald (40)



Smoked (34)



Black (14)



Amber (11)



Clear (10)



Blue (09)

METAL FINISHES



Copper
(CO)



Silver (FP)



Silver/White
Patina
(FP/PB)



Lead (CH)



Palladium
(PL)



Black (PR)



Gold/White
Patina
(FO/PB)



Gold (FO)



Talha (TA)

SERIP

Diamond Nubia

REFERENCE 6015



DESCRIPTION

Inspired by handcrafted jewellery. The Diamond Collection highlights a sense of luxury through the brightness of its imperial display. Opulent and extravagant, the collection reminisces on the hypnotizing glow of Sapphires, Emeralds, Ambar and Rubies. The rings of metal branches were carefully designed to incorporate nearly hundreds of gleaming stones, all for a final result of incredible shine and class, increasing to the measure of its length. Ideal for classic interiors, framing perfectly in bedrooms, dining and living rooms.

Finish shown here Metal FO | Glass 10+14+34

Designed and produced by hand in Portugal.

Serip reserves the right to make changes or improvements at any time it deems useful to guarantee the highest quality standards for its products.

Hand-finished, some variations may occur.

All the glass models are designed by Serip and exclusively handmade produced, establishing a unique and prestigious feature of the glass handwork art. For this reason, there is the possibility of variation in measures, weight, colour and shape represented.

TECHNICAL DRAWING

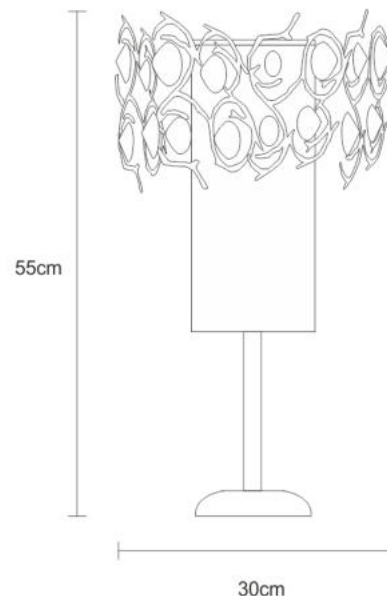

TECHNICAL SPECIFICATIONS

MEASUREMENTS

Height 55cm / 22in

Weight 5kg / 11lb

PACKAGE SIZE & WEIGHT

(m)Package 1/2 0.64cm x 0.46cm x 0.64cm
=0.19CBM

(in)Package 1/2 0.25in x 0.18in x 0.25in
=6.65US GAL

ELECTRIC FEATURE

Installation Table Lamp
IP degree IP 20

220-240V 50Hz-60Hz
Max Power Consumption 160W
Light Sources
4 x G9 Max 40W

Included Sources

Light Sources
4 x G9 LED 2W
Lumens 920lm
Kelvin 3000
CRI 80

110-120V 50Hz-60Hz
Max Power Consumption 160W
Light Sources
4 x G9 Max 40W

ENERGY RATING

This luminaire allows lights sources with energy efficiency class

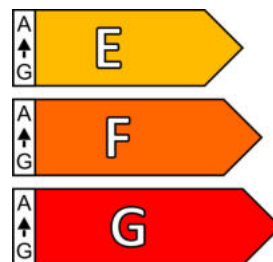

CERTIFICATIONS



CARE INSTRUCTIONS

Due to the nature of our exquisite hand applied finishes, wipe clean with a soft, dry cloth or static duster must be used to clean the fixture.

Always avoid the use of harsh chemicals or abrasive cleaners as they may cause damage to the fixture's finish.

Cleaning is limited to the outer surfaces, shades or glass. It is important to ensure that no moisture enters the terminal compartment or reaches any live parts.

As our products are subject to technical modifications, we cannot guarantee, that all information is always up to date. Please contact our [technical department](#) with any queries.

SERIP

OPTIONAL FINISHES

GLASS FINISHES



Emerald (40)



Smoked (34)



Black (14)



Amber (11)



Clear (10)



Blue (09)

METAL FINISHES



Copper
(CO)



Silver (FP)



Silver/White
Patina
(FP/PB)



Lead (CH)



Palladium
(PL)



Black (PR)



Gold/White
Patina
(FO/PB)



Gold (FO)



Talha (TA)

SERIP

SERIP

Diamond Veil Quadruple

REFERENCE CT3308/36



DESCRIPTION

Inspired by handcrafted jewellery. The Diamond Collection highlights a sense of luxury through the brightness of its imperial display. Opulent and extravagant, the collection reminisces on the hypnotizing glow of Sapphires, Emeralds, Ambar and Rubies. The rings of metal branches were carefully designed to incorporate nearly hundreds of gleaming stones, all for a final result of incredible shine and class, increasing to the measure of its length. Ideal for classic interiors, framing perfectly in bedrooms, dining and living rooms.

Finish shown here Metal FP | Glass 10+12+14

Designed and produced by hand in Portugal.

Serip reserves the right to make changes or improvements at any time it deems useful to guarantee the highest quality standards for its products.

Hand-finished, some variations may occur.

All the glass models are designed by Serip and exclusively handmade produced, establishing a unique and prestigious feature of the glass handwork art. For this reason, there is the possibility of variation in measures, weight, colour and shape represented.

TECHNICAL DRAWING

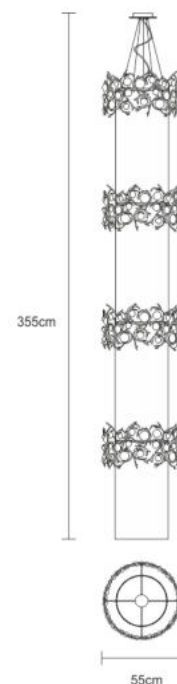

SERIP

TECHNICAL SPECIFICATIONS

MEASUREMENTS

Height 315cm / 124in
OAH Overall Height Min 355cm / 140in
OAH Overall Height Max 375cm / 148in
Weight 55kg / 121lb

PACKAGE SIZE & WEIGHT

(m)Package 1/2 0.85cm x 1.00cm x 2.03cm
=1.73CBM
(in)Package 1/2 0.33in x 0.39in x 0.80in
=60.93US GAL

ELECTRIC FEATURE

Installation Ceiling
IP degree IP 20

220-240V 50Hz-60Hz
Max Power Consumption 1440W
Light Sources
36 x G9 Max 40W

Included Sources
Light Sources
36 x G9 LED 2W
Lumens 8280lm
Kelvin 3000
CRI 80

Optional Sources
Light Sources
36 x G9 LED 3W
Lumens 10800lm
Kelvin 3000
CRI 80

110-120V 50Hz-60Hz
Max Power Consumption 1440W
Light Sources
36 x G9 Max 40W

ENERGY RATING

This luminaire allows lights sources with energy efficiency class

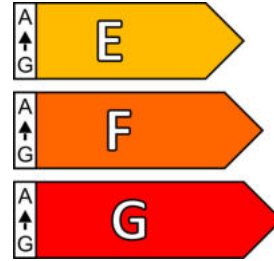

CERTIFICATIONS



CARE INSTRUCTIONS

Due to the nature of our exquisite hand applied finishes, wipe clean with a soft, dry cloth or static duster must be used to clean the fixture.

Always avoid the use of harsh chemicals or abrasive cleaners as they may cause damage to the fixture's finish.

Cleaning is limited to the outer surfaces, shades or glass. It is important to ensure that no moisture enters the terminal compartment or reaches any live parts.

As our products are subject to technical modifications, we cannot guarantee, that all information is always up to date. Please contact our [technical department](#) with any queries.

SERIP

OPTIONAL FINISHES

GLASS FINISHES



Emerald (40)



Smoked (34)



Black (14)



Amber (11)



Clear (10)



Blue (09)

METAL FINISHES



Copper
(CO)



Silver (FP)



Silver/White
Patina
(FP/PB)



Lead (CH)



Palladium
(PL)



Black (PR)



Gold/White
Patina
(FO/PB)



Gold (FO)



Talha (TA)

SERIP

Diamond Dynastes Granti

REFERENCE AP1411/3

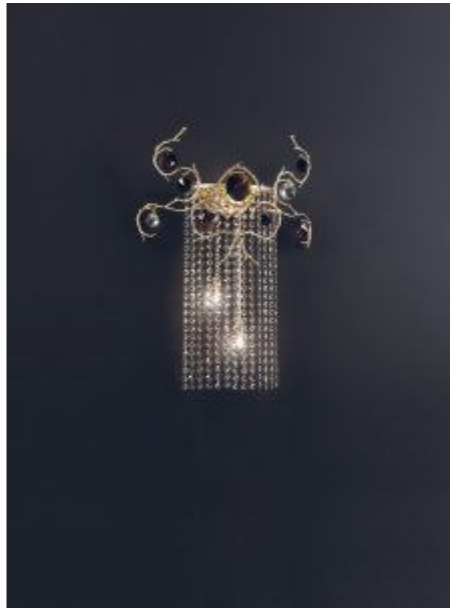

DESCRIPTION

Inspired by handcrafted jewellery. The Diamond Collection highlights a sense of luxury through the brightness of its imperial display. Opulent and extravagant, the collection reminisces on the hypnotizing glow of Sapphires, Emeralds, Ambar and Rubies. The rings of metal branches were carefully designed to incorporate nearly hundreds of gleaming stones, all for a final result of incredible shine and class, increasing to the measure of its length. Ideal for classic interiors, framing perfectly in bedrooms, dining and living rooms.

Finish shown here Metal FP | Glass 10+12+14+34

Designed and produced by hand in Portugal.

Serip reserves the right to make changes or improvements at any time it deems useful to guarantee the highest quality standards for its products.

Hand-finished, some variations may occur.

All the glass models are designed by Serip and exclusively handmade produced, establishing a unique and prestigious feature of the glass handwork art. For this reason, there is the possibility of variation in measures, weight, colour and shape represented.

TECHNICAL DRAWING

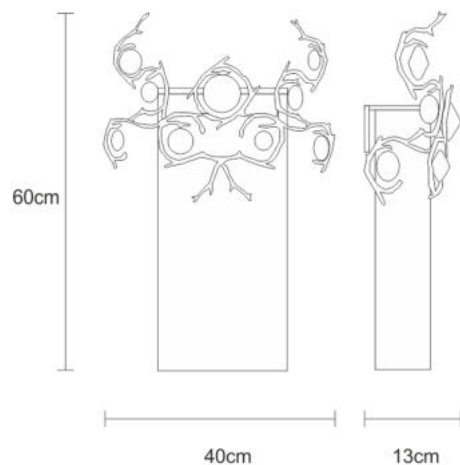

TECHNICAL SPECIFICATIONS

MEASUREMENTS

FIXTURE SIZE & WEIGHT

Width 40cm / 16in
Height 60cm / 24in
Depth 13cm / 5in
Weight 3kg / 7lb

PACKAGE SIZE & WEIGHT

(m)Package 1/2 0.64cm x 0.46cm x 0.64cm
=0.19CBM
(in)Package 1/2 0.25in x 0.18in x 0.25in
=6.65US GAL

ELECTRIC FEATURE

Installation Wall
IP degree IP 20

220-240V 50Hz-60Hz
Max Power Consumption 120W
Light Sources
3 x G9 Max 40W

Included Sources

Light Sources
3 x G9 LED 2W
Lumens 690lm
Kelvin 3000
CRI 80

Optional Sources

Light Sources
3 x G9 LED 3W
Lumens 900lm
Kelvin 3000
CRI 80

110-120V 50Hz-60Hz
Max Power Consumption 120W
Light Sources
3 x G9 Max 40W

ENERGY RATING

This luminaire allows lights sources with energy efficiency class

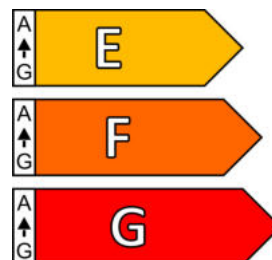

CERTIFICATIONS



CARE INSTRUCTIONS

Due to the nature of our exquisite hand applied finishes, wipe clean with a soft, dry cloth or static duster must be used to clean the fixture.

Always avoid the use of harsh chemicals or abrasive cleaners as they may cause damage to the fixture's finish.

Cleaning is limited to the outer surfaces, shades or glass. It is important to ensure that no moisture enters the terminal compartment or reaches any live parts.

As our products are subject to technical modifications, we cannot guarantee, that all information is always up to date. Please contact our [technical department](#) with any queries.

SERIP

OPTIONAL FINISHES

GLASS FINISHES



Emerald (40)



Smoked (34)



Black (14)



Amber (11)



Clear (10)



Blue (09)

METAL FINISHES



Copper
(CO)



Silver (FP)



Silver/White
Patina
(FP/PB)



Lead (CH)



Palladium
(PL)



Black (PR)



Gold/White
Patina
(FO/PB)



Gold (FO)



Talha (TA)

SERIP

Diamond Dynastes Maya

REFERENCE AP1411/2

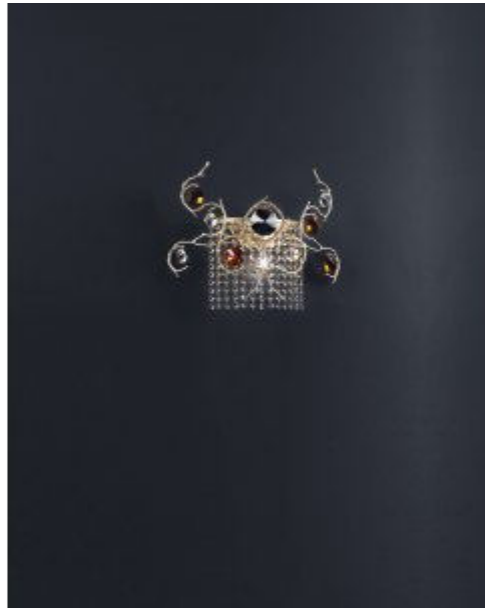

DESCRIPTION

Inspired by handcrafted jewellery. The Diamond Collection highlights a sense of luxury through the brightness of its imperial display. Opulent and extravagant, the collection reminisces on the hypnotizing glow of Sapphires, Emeralds, Ambar and Rubies. The rings of metal branches were carefully designed to incorporate nearly hundreds of gleaming stones, all for a final result of incredible shine and class, increasing to the measure of its length. Ideal for classic interiors, framing perfectly in bedrooms, dining and living rooms.

Finish shown here Metal FP | Glass 10+11+34

Designed and produced by hand in Portugal.

Serip reserves the right to make changes or improvements at any time it deems useful to guarantee the highest quality standards for its products.

Hand-finished, some variations may occur.

All the glass models are designed by Serip and exclusively handmade produced, establishing a unique and prestigious feature of the glass handwork art. For this reason, there is the possibility of variation in measures, weight, colour and shape represented.

TECHNICAL DRAWING

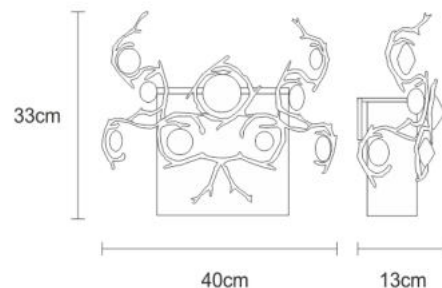

TECHNICAL SPECIFICATIONS

MEASUREMENTS

FIXTURE SIZE & WEIGHT

Width 40cm / 16in

Height 33cm / 13in

Depth 13cm / 5in

Weight 2kg / 4lb

PACKAGE SIZE & WEIGHT

(m)Package 1/2 0.64cm x 0.46cm x 0.64cm
=0.19CBM

(in)Package 1/2 0.25in x 0.18in x 0.25in
=6.65US GAL

ELECTRIC FEATURE

Installation Wall
IP degree IP 20

220-240V 50Hz-60Hz
Max Power Consumption 80W
Light Sources
2 x G9 Max 40W

Included Sources

Light Sources
2 x G9 LED 2W
Lumens 460lm
Kelvin 3000
CRI 80

Optional Sources

Light Sources
2 x G9 LED 3W
Lumens 600lm
Kelvin 3000
CRI 80

110-120V 50Hz-60Hz
Max Power Consumption 80W
Light Sources
2 x G9 Max 40W

ENERGY RATING

This luminaire allows lights sources with energy efficiency class

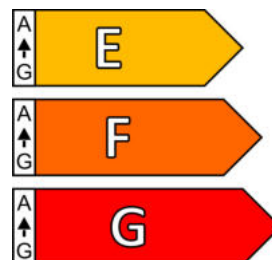

CERTIFICATIONS



CARE INSTRUCTIONS

Due to the nature of our exquisite hand applied finishes, wipe clean with a soft, dry cloth or static duster must be used to clean the fixture.

Always avoid the use of harsh chemicals or abrasive cleaners as they may cause damage to the fixture's finish.

Cleaning is limited to the outer surfaces, shades or glass. It is important to ensure that no moisture enters the terminal compartment or reaches any live parts.

As our products are subject to technical modifications, we cannot guarantee, that all information is always up to date. Please contact our [technical department](#) with any queries.

SERIP

OPTIONAL FINISHES

GLASS FINISHES



Emerald (40)



Smoked (34)



Black (14)



Amber (11)



Clear (10)



Blue (09)

METAL FINISHES



Copper
(CO)



Silver (FP)



Silver/White
Patina
(FP/PB)



Lead (CH)



Palladium
(PL)



Black (PR)



Gold/White
Patina
(FO/PB)



Gold (FO)



Talha (TA)

SERIP

SERIP

Diamond Pharaoh

REFERENCE CT3246/10



DESCRIPTION

Inspired by handcrafted jewellery. The Diamond Collection highlights a sense of luxury through the brightness of its imperial display. Opulent and extravagant, the collection reminisces on the hypnotizing glow of Sapphires, Emeralds, Ambar and Rubies. The rings of metal branches were carefully designed to incorporate nearly hundreds of gleaming stones, all for a final result of incredible shine and class, increasing to the measure of its length. Ideal for classic interiors, framing perfectly in bedrooms, dining and living rooms.

Finish shown here Metal FP | Glass 10+14+34

Designed and produced by hand in Portugal.

Serip reserves the right to make changes or improvements at any time it deems useful to guarantee the highest quality standards for its products.

Hand-finished, some variations may occur.

All the glass models are designed by Serip and exclusively handmade produced, establishing a unique and prestigious feature of the glass handwork art. For this reason, there is the possibility of variation in measures, weight, colour and shape represented.

TECHNICAL DRAWING

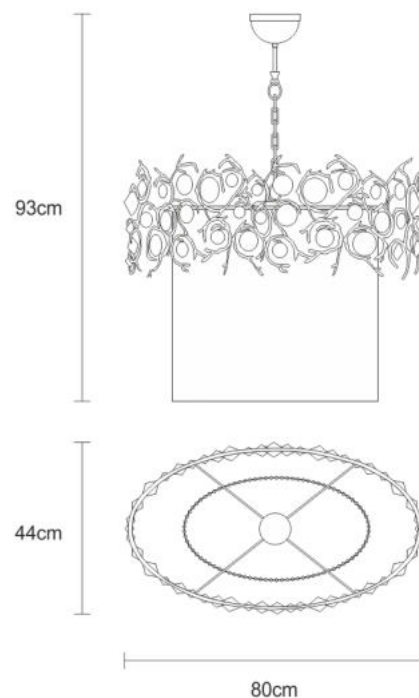

SERIP

TECHNICAL SPECIFICATIONS

MEASUREMENTS

FIXTURE SIZE & WEIGHT

Width 44cm / 17in

Height 63cm / 25in

Length 80cm / 31in

OAH Overall Height Min 93cm / 37in

OAH Overall Height Max 113cm / 44in

Weight 12kg / 26lb

PACKAGE SIZE & WEIGHT

(m)Package 1/2 1.18cm x 1.00cm x 1.20cm

=1.42CBM

(in)Package 1/2 0.46in x 0.39in x 0.47in

=50.00US GAL

ELECTRIC FEATURE

Installation Ceiling

IP degree IP 20

220-240V 50Hz-60Hz

Max Power Consumption 400W

Light Sources

10 x G9 Max 40W

Included Sources

Light Sources

10 x G9 LED 2W

Lumens 2300lm

Kelvin 3000

CRI 80

Optional Sources

Light Sources

10 x G9 LED 3W

Lumens 3000lm

Kelvin 3000

CRI 80

110-120V 50Hz-60Hz

Max Power Consumption 400W

Light Sources

10 x G9 Max 40W

ENERGY RATING

This luminaire allows lights sources with energy efficiency class



CERTIFICATIONS



CARE INSTRUCTIONS

Due to the nature of our exquisite hand applied finishes, wipe clean with a soft, dry cloth or static duster must be used to clean the fixture.

Always avoid the use of harsh chemicals or abrasive cleaners as they may cause damage to the fixture's finish.

Cleaning is limited to the outer surfaces, shades or glass. It is important to ensure that no moisture enters the terminal compartment or reaches any live parts.

As our products are subject to technical modifications, we cannot guarantee, that all information is always up to date. Please contact our [technical department](#) with any queries.

SERIP

OPTIONAL FINISHES

GLASS FINISHES



Emerald (40)



Smoked (34)



Black (14)



Amber (11)



Clear (10)



Blue (09)

METAL FINISHES



Copper
(CO)



Silver (FP)



Silver/White
Patina
(FP/PB)



Lead (CH)



Palladium
(PL)



Black (PR)



Gold/White
Patina
(FO/PB)



Gold (FO)



Talha (TA)

SERIP

SERIP

Diamond Kurus

REFERENCE CT3251/16



DESCRIPTION

T

Inspired by handcrafted jewellery. The Diamond Collection highlights a sense of luxury through the brightness of its imperial display. Opulent and extravagant, the collection reminisces on the hypnotizing glow of Sapphires, Emeralds, Ambar and Rubies. The rings of metal branches were carefully designed to incorporate nearly hundreds of gleaming stones, all for a final result of incredible shine and class, increasing to the measure of its length. Ideal for classic interiors, framing perfectly in bedrooms, dining and living rooms.

Finish shown here Metal FO | Glass 10+14

Designed and produced by hand in Portugal.

Serip reserves the right to make changes or improvements at any time it deems useful to guarantee the highest quality standards for its products.

Hand-finished, some variations may occur.

All the glass models are designed by Serip and exclusively handmade produced, establishing a unique and prestigious feature of the glass handwork art. For this reason, there is the possibility of variation in measures, weight, colour and shape represented.

SERIP

TECHNICAL SPECIFICATIONS

MEASUREMENTS

FIXTURE SIZE & WEIGHT

Width 40cm / 16in

Height 30cm / 12in

Length 135cm / 53in

OAH Overall Height Min 70cm / 28in

OAH Overall Height Max 320cm / 126in

Weight 24kg / 53lb

PACKAGE SIZE & WEIGHT

(m)Package 1/2 0.75cm x 0.80cm x 1.60cm

=0.96CBM

(in)Package 1/2 0.30in x 0.31in x 0.63in

=33.90US GAL

ELECTRIC FEATURE

Installation Ceiling

IP degree IP 20

220-240V 50Hz-60Hz

Max Power Consumption 640W

Light Sources

16 x G9 Max 40W

Included Sources

Light Sources

16 x G9 LED 2W

Lumens 3680lm

Kelvin 3000

CRI 80

Optional Sources

Light Sources

16 x G9 LED 3W

Lumens 4800lm

Kelvin 3000

CRI 80

110-120V 50Hz-60Hz

Max Power Consumption 640W

Light Sources

16 x G9 Max 40W

ENERGY RATING

This luminaire allows lights sources with energy efficiency class



CERTIFICATIONS



CARE INSTRUCTIONS

Due to the nature of our exquisite hand applied finishes, wipe clean with a soft, dry cloth or static duster must be used to clean the fixture.

Always avoid the use of harsh chemicals or abrasive cleaners as they may cause damage to the fixture's finish.

Cleaning is limited to the outer surfaces, shades or glass. It is important to ensure that no moisture enters the terminal compartment or reaches any live parts.

As our products are subject to technical modifications, we cannot guarantee, that all information is always up to date. Please contact our [technical department](#) with any queries.

SERIP

OPTIONAL FINISHES

GLASS FINISHES



Emerald (40)



Smoked (34)



Black (14)



Amber (11)



Clear (10)



Blue (09)

METAL FINISHES



Copper
(CO)



Silver (FP)



Silver/White
Patina
(FP/PB)



Lead (CH)



Palladium
(PL)



Black (PR)



Gold/White
Patina
(FO/PB)



Gold (FO)



Talha (TA)

SERIP